

Operating Manual

# HDTV receiver for satellite reception UFS 902



---

**KATHREIN**  
Antennen • Electronic

## FOREWORD/IMPORTANT INFORMATION

Dear customer,

this Operating Manual is intended to help you make the fullest use of the extensive range of functions offered by your new HDTV satellite receiver.

We have tried to make the operating instructions as easy as possible to understand, and to keep them as concise as possible. To help you understand particular specialist terms that cannot be translated, we have added a short glossary at the end of the manual.

The power switch is an environmentally friendly feature. If you will not be using your receiver for an extended period, you should use the power switch to disconnect it from the power supply and save energy. For shorter breaks, you can use the remote control to switch the receiver to standby, which uses only a minimal amount of energy.

We wish you good reception and much pleasure using your new DVB HDTV satellite receiver.

Your  
KATHREIN team

### RECORDING FUNCTION (FROM SOFTWARE VERSION 1.02)

From software version 1.02 the UFS 902 can make recordings on to external USB storage media. These standard instructions for the UFS 902 do not include a detailed description of the recording capabilities/functions.

Separate "Instructions for the USB interface" are available, which give details of making and managing these recordings and give guidance regarding issues to be dealt with when connecting USB storage media to the UFS 902. The instructions and also the software are available from the following address on the Internet for downloading to your PC/laptop:

"www.kathrein.de" ("Service" → "Software and Download" → "Receiver" → "UFS 902" → "Software and Firmware")

Instructions are also available there for using a USB memory stick to load the new software on to the receiver.

### INFORMATION ON AUDIO MPEG INC. AND S.I.SV.EL, S.P.A:

This unit makes use of legally protected technologies, which are protected by patents in the USA and also by other intellectual property rights in other countries.

KATHREIN-Werke KG has obtained licences from Audio MPEG Inc. and Societa' Italiana per lo sviluppo dell'elettronica, S.I.SV.EL, S.P.A to use these technologies. These licences carry certain restrictions, which apply also to you as the customer.

Accordingly this unit may be used by the end customer only for private non-commercial purposes and for the licensed content. It may not be used for commercial purposes. The use of products or processes that are sold or used with this unit is not included in this statement. The use of reverse engineering is not permitted in respect of the licensed technologies, nor is disassembly.

### SWITCHING THE RECEIVER OFF

Before you switch off the receiver using the power switch, you must switch the remote control into stand-by

mode by pressing the stand-by button (Ⓞ). In stand-by mode, any changed data that is broadcast will be saved by the receiver. Once the receiver is in stand-by mode it can be fully switched off at any time at the power switch at the rear of the unit.

## FOREWORD/IMPORTANT INFORMATION



**Do not switch the receiver off at the power switch directly from the operating mode! This can lead to loss of data and corruption of the software.**

The channels available on the satellites and transponders are subject to continual change. In such cases, it is necessary to re-adjust the channels as the factory preset programming corresponds to the situation on the date of manufacture. The information for these settings can be found on the Internet or in relevant magazines.

Your receiver is equipped in the factory with the latest software version. We are however constantly working on adapting the software to the wishes of our customers and to developments in technology. The “Software and Channel List Update” section contains additional information.

**Please keep the original packaging in case you need to return the product at any time!**

**Any modifications to the receiver software will invalidate the warranty!**

**You will have to bear the costs yourself for dispatching and repairing any receiver that requires attention due to modifications to the software other than those provided by Kathrein!**

**Therefore exclusively use software provided by Kathrein for your receiver. This is available by downloading from the satellite or from the Internet ([www.kathrein.de](http://www.kathrein.de)).**

**The standby power consumption of < 1 W printed on the receiver packaging is achieved only when the receiver is in stand-by mode with the display switched off. You can perform the setting in the following menu: “Main menu”, “Settings”, “Customize screen menu”, “Front display in standby”**

**The information in this operating manual was correct at the time of going to press. We reserve the right however to make changes at any time and without prior notice. If new software is released for your receiver, and this affects the information in the operating manual (e.g. changes to the menus and/or functions), if we believe it necessary we will make available a new operating manual for download under “[www.kathrein.de](http://www.kathrein.de)”.**

**Make a note of the receiver's basic settings, so as to be able to restore them if necessary!**

**Included in the software for this receiver is software that is licensed under the GNU (General Public Licence). You can find out how to obtain the source code for the program at: <http://www.kathrein.de/linux/receiver/ufs902>**

**The term DiSEqC™ used in this operating manual is a registered trade mark of the European Telecommunication Satellite Organization (EUTELSAT).**

## DISPOSAL INSTRUCTIONS



Electronic equipment is not domestic waste - in accordance with directive 2002/96/EC OF THE EUROPEAN PARLIAMENT AND THE COUNCIL dated 27<sup>th</sup> January 2003 on used electrical and electronic appliances, it must be disposed of properly.

At the end of its service life, take this unit for disposal to an appropriate official collection point.

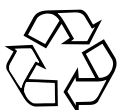

**Used batteries are special waste!**

Do not throw spent batteries into your domestic waste; take them to a collection point for used batteries!

## RECEIVER FEATURES/PRODUCT PACKAGE

The UFS 902 HDTV receiver is suitable for the reception of digital satellite TV and radio channels. The receiver can be used to receive both high resolution and also conventional TV.

The built-in Common Interface offers capacity for one CA module for pay TV channels. The receiver indicates the channel name on the 12-character alphanumeric display.

The HDMI interface allows the receiver to be connected to a HDTV-capable TV set. In addition one YpbPr connection and one Scart connection (TV) are provided. Via the optical audio output, the receiver can output the Dolby Digital data stream AC 3 to a Dolby Digital system.

The integrated Kathrein Convenience EPG is not only a clearly laid out electronic TV guide, but also enables programmes to be copied directly from the related EPG view to the timer.

The USB 2.0 host port on the rear of the unit allows software updates to be loaded to the receiver.

## PRODUCT PACKAGE

- Receiver UFS 902 (silver or black)
- Infra-red remote control
- Batteries
- HDMI cable
- Operating manual
- Safety instructions
- Scart cable
- Mains power cable

## SWITCHING OFF THE RECEIVER AND UPDATING THE EPG

By pressing the  button you can switch the receiver out of TV mode to the standby mode, and back again.

The receiver has the facility to update the EPG overnight, i.e. at 03:00 the receiver automatically starts to update the EPG data. If the receiver is in operation at this time, the update is postponed until 03:00 the following night.

**The update time cannot be changed.**

During the update, the EPG data for all channels listed in the favourite lists, together with the first 25 channels in the overall channel list are updated. However, this update is only performed if the receiver is in the standby mode. If the receiver is completely switched off (at the mains) or if it is in operation, the update will be delayed (see above). After updating the data, the receiver automatically switches back to the standby mode.

By pressing the  button you can interrupt the update before it is finished; the receiver then switches immediately to the standby mode.

# CONTENTS

FOREWORD/IMPORTANT INFORMATION .....	2
RECEIVER FEATURES/PRODUCT PACKAGE .....	4
CONTENTS.....	5
SAFETY INSTRUCTIONS - IMPORTANT INFORMATION .....	6
CONTROLS, DISPLAYS AND CONNECTIONS .....	7
CONNECTION AND SETUP .....	8
REMOTE CONTROL.....	10
FIRST INSTALLATION .....	12
OPERATING INSTRUCTIONS .....	29
ON-SCREEN DISPLAYS (OSD) .....	32
EPG - ELECTRONIC PROGRAMME GUIDE.....	36
COMMON INTERFACE .....	47
TELETEXT .....	49
EDITING CHANNEL LIST.....	50
SEARCHING FOR CHANNELS (CHANNEL SEARCH).....	56
PARENTAL CONTROL.....	62
SETTINGS .....	63
SERVICE MENU .....	68
OPERATING FROM THE FRONT PANEL .....	72
TECHNICAL APPENDIX.....	73
SHORT TECHNICAL GLOSSARY.....	80
SUBJECT INDEX.....	84
TROUBLESHOOTING.....	86
FOR YOUR NOTES .....	87

# SAFETY INSTRUCTIONS - IMPORTANT INFORMATION

GB

## Safety Instructions – Important Information

*This page contains important information about the operation, installation location and connection of the unit. Read these instructions carefully before starting to use the unit.*

---



**DANGER!**

### Mains cable

Make sure that the mains cable (power supply cable) is not damaged. Units with a damaged mains cable must be disconnected from the mains (disconnect mains connector) and repaired by a qualified engineer before setup. Only use the power pack supplied (if available)!

*Risk of death due to electric shock!*

### Cleaning

Disconnect the mains connector before cleaning the unit. Only use a dry cloth for cleaning and only clean the outer surface. Never open the unit.

*Touching the parts inside the unit carries a risk of death due to electric shock!*

### Playing children

Make sure that children do not push any objects into the ventilation slots.

*Risk of death due to electric shock!*

---



**WARNING!**

### Earth connection

The antenna system must be earthed as specified or equipotentially bonded. EN 60728/11 and any national regulations must be complied with.

*Danger due to surge voltages, lightning strikes!*

### Mains voltage

Only operate the unit with the specified mains voltage (marked on the rear of the unit or on the external power pack)! The unit may only be connected to the mains and turned on once it has been connected to the antenna and to the TV set or the cable network and PC.

*If the mains voltage is too high, there is a risk of fire!*

### Repairs

Ensure that any repairs to your unit are carried out by qualified personnel. Opening the unit and attempting to repair it yourself voids all warranty claims! Improper work on the unit can jeopardise the electrical safety of the unit.

*The manufacturer accepts no liability for accidents caused by the user opening the unit!*

---



**CAUTION!**

### Connections

Incorrect wiring of the connections can lead to malfunctions or defects on the unit!

### Long periods of absence/storms/accessibility of the mains connector

Always turn off the unit at the mains switch if you will be absent for a long time or there is a storm. Disconnect it from the mains by unplugging the mains connector. This also applies to the other equipment connected to the unit. Isolation from the cable network is also recommended. Note any timer programs (receiver) and turn the unit on again promptly before the recording time. Ensure the mains connector is accessible at all times.



### Installation location

All electronic equipment generates heat. However, the heating of this unit lies within the permissible range. Sensitive furniture surfaces and veneers may become discoloured by the effects of constant heat over time. The feet of the unit can also cause colour changes to treated furniture surfaces. If necessary, place the unit on a suitable stable and flat base!



### Ventilation

The heat generated in this unit is adequately dissipated. However, the unit should never be installed in a cupboard or on shelves with inadequate ventilation. Never cover the cooling slots on the unit (e.g. with other equipment, magazines, tablecloths or curtains)!

Do not place any objects on top of the unit and maintain a clearance of at least 10 cm above the unit, so that the heat generated can be dissipated with no obstructions.

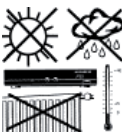

### Moisture, sunlight, heat, naked flames

Protect the unit against moisture, dripping and splashed water (do not place any filled objects such as vases on top of the unit). Do not place the unit close to a heater or expose it to direct sunlight and do not operate it in damp locations. Only use the unit in a moderate climate, not in tropical conditions! Do not expose the unit to any naked flame, such as from a candle! This constitutes a fire hazard!

---

# CONTROLS, DISPLAYS AND CONNECTIONS

This section provides a brief description of all the controls, displays and connections. The button symbols presented here can also be found in the description of the operating steps.

## VIEW OF FRONT PANEL (FLAP FOLDED DOWN)

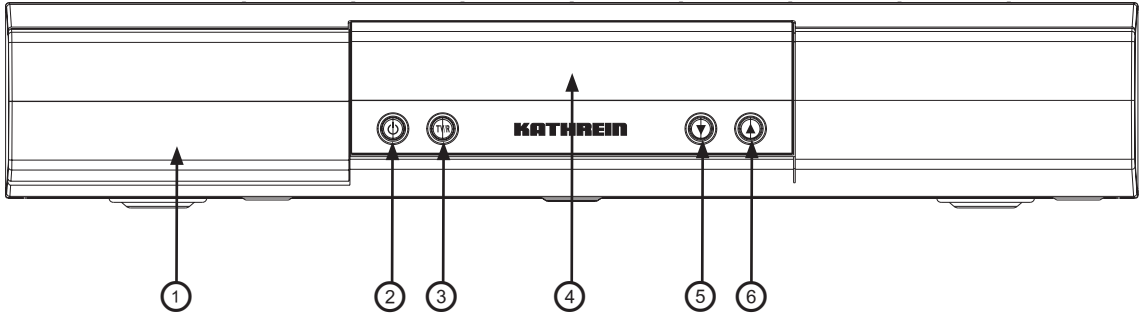

## VIEW OF REAR PANEL

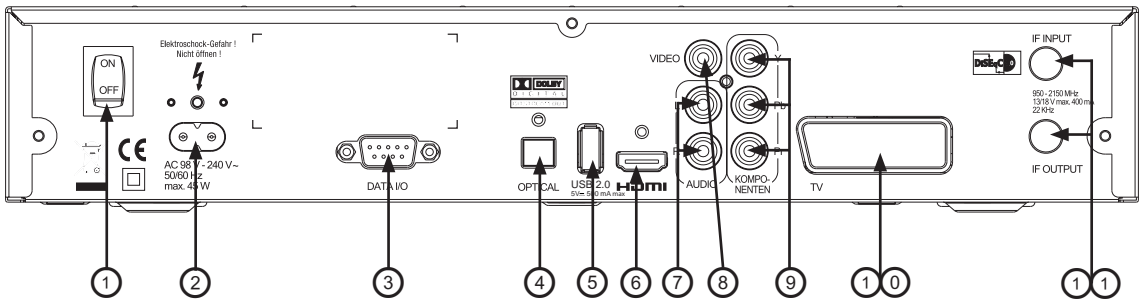

### Front panel controls and displays

1. Common Interface for one CA module for pay TV cards \*) (behind the flap)
2. Stand-by button
3. TV/R button
4. Display
- 5/6. Arrow buttons for changing channel

### Rear panel controls and displays

1. On/Off switch (with mains disconnect)
2. Mains power cable
3. RS 232 port (for Service only)
4. Optical data stream output (SPDIF/ Sony Philips Digital Interface Format) for Dolby Digital AC 3 audio
5. USB 2.0 port (USB-A connector)
6. HDMI socket for connection to a TV set
7. 2 x Cinch plug audio outputs (L/R)
8. Cinch plug video output (composite colour)
9. 3 x Cinch connections for component outputs YUV labelled = Y/Pb/Pr
10. Scart socket for TV connection
11. 2 x SAT-IF connections (input above/ loop-through output below)

\*) The CA module and pay TV cards are not included

## CONNECTION AND SETUP

The following section is intended specifically for specialist dealers. You need not refer to this section unless you are carrying out the installation yourself.

The "Connection Examples" section provides a sample configuration.

Do not connect the receiver to the power supply until all installation work has been properly carried out. Refer to the information in the "Safety Instructions" section.

### CONNECTING THE UNIT (SAT IF CONNECTIONS)



Connect the Sat IF input on the receiver to the satellite reception system. Use a coaxial cable with a standard F connector.

If the F standard connectors are not yet fitted on the cable, strip the insulation from the cable as shown in the following illustration and carefully twist the F standard connectors on to the ends of the cables until they are securely seated.

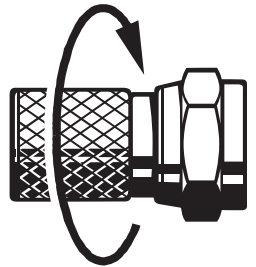

When fitting the connector, make sure that no wires from the braid are touching the inner conductor, so no short circuit can occur.

The quality of the reception signal depends on this connection!

### RECEPTION REQUIREMENTS



Make sure that your satellite antenna system is equipped at least with a universal LNB for digital reception in the high-band range.

### RECEPTION SYSTEM PRESETS

The presets for the control signals have been made for standard reception systems, i.e. 14/18 V for polarity reversal and 22 kHz switching signal for low/high band changeover on multi-feed reception systems.



## CONNECTION AND SETUP

### TV CONNECTION

Connect the satellite receiver (HDMI or alternatively TV Scart socket) and the TV set using a HDMI or Scart cable (see "Connection Example"). If your TV is stereo, you can receive the sound in stereo via the HDMI or Scart connection.

For system reasons, the same video signals are to be found at the TV Scart socket as at the video cinch output.

### AUDIO CONNECTION

If you want to play the sound on your hi-fi system, connect the audio cinch sockets to the input sockets on the hi-fi system, using an appropriate cable (see "Connection Example").

### OPTICAL/ELECTRICAL DIGITAL OUTPUT

The fibre-optic output is intended for the connection of a Dolby Digital system (see "Connection Example").

### INSERTING BATTERIES IN THE REMOTE CONTROL

Remove the cover on the rear of the remote control.

Insert the two batteries supplied into the remote control. Ensure correct polarity of the batteries; the + and - markings are indicated inside the battery compartment.

Slide the cover back into the housing until it locks in place.

# REMOTE CONTROL

 Sound on/off

 Enter numbers for channels, timer etc.

 Open main menu, leave the menu and return to the TV picture

 Open favourites selection

 1x open display of 4:3 programmes, 2x open HDMI/YUV format

 Volume

 Leave menu step by step

 Change channel in the programme preview (EPG)

 Currently not used

 Currently not used



 Stand-by

 Teletext

 (yellow)  
Open channel options sound/subtitles selection

 (blue)  
Media selection

 Open channel OSD channel information

 Channel selection up/down

 Confirm entry open channel list

 Cursor buttons

 Open EPG (Electronic Programme Guide)

 Change channel in the programme preview (EPG)

The button symbols shown here can also be found in the description of the operating steps.

# REMOTE CONTROL

## REMOTE CONTROL RC 660

The RC 660 remote control supports up to four units which are supplied as standard with the RC 660.

First switch off all other receivers at the power switch.

### 1. Set-up using menu

On the UFS 902 the remote control code on the "Service Menu", "Remote Control Code" menu is changed.









**Note:** *The remote control code can only be changed using the menu. Manual changes are not saved by the receiver.*

### 2. Manual set-up (not possible on UFS 902)

Switch on the relevant receiver.

On the remote control simultaneously press









address 1 =  +  + 



Then switch the receiver off again at the power switch and do the same for the other units ( +  +   
for the second receiver;  +  +  for the third receiver and  +  +  for the fourth receiver)

Make sure only one receiver is on at a time!

To switch the remote control to an infrared code:

When you have configured all receivers to their infrared code, to switch between units on the remote control do the following:

For operating the first receiver (address 1), press  +  , for the second receiver  +  , for the third receiver  +  and for the fourth receiver  +  .

 +  (red) = Kathrein UFD 5xx code for remote control RC 400

The RC 600 and RC 650 remote controls are not interchangeable!

# FIRST INSTALLATION

Before using your receiver for the first time, read the “Safety Instructions” and “Connection and Setup” sections.

The “Connection Examples” section provides a sample configuration.



Do not connect the receiver to the power supply until all installation work has been properly carried out.

The guidance given in the “First Installation” section assumes that the receiver has been properly connected as per the “Safety Instructions” and “Connection and Set-Up” sections.

First switch your TV set on and select the AV channel slot. Switch on your receiver at the power switch at the rear of the unit. The following display appears:

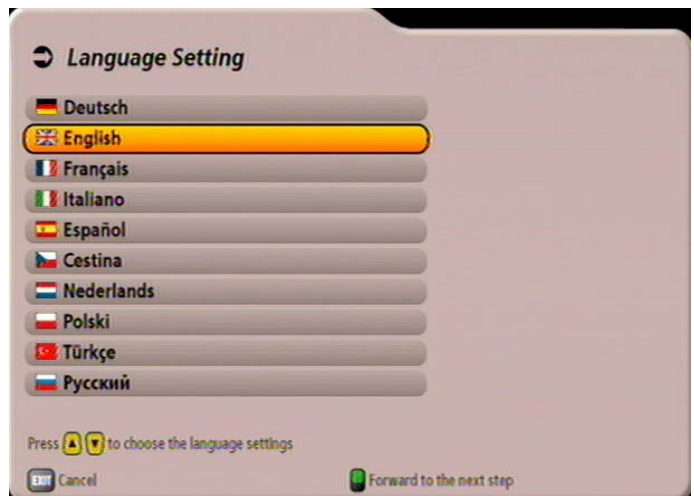

Also note the bars at the bottom of the on-screen display! These provide information on what to do next.

Select the menu language you want using the   buttons. Available options: German, English, French, Italian, Spanish, Czech, Dutch, Polish, Turkish and Russian.





Press the  (green) button to move to the next menu.

**Note:** *If you are unsure whether you chose the right option from a previous menu, you can go back a step at any time during the first installation process by pressing the  (red) button.*

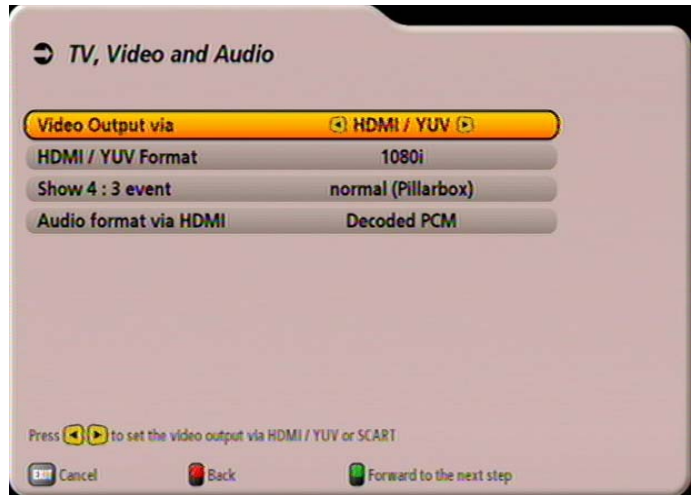
# FIRST INSTALLATION

The following display appears:



Use the     buttons here to select the settings for your TV set.

**When doing this, refer to the operating instructions for your TV set!**

## Video Output via

Select here the connection on the receiver to which you have connected your television. Either

### SCART

or

### HDMI/YUV

#### TV aspect ratio

Here you select the TV's picture format. Either

- 4:3 or
- 16:9

#### Picture format

Select here the type of screen display, depending on the setting of your TV format:

- TV format "4:3": Pan & Scan or Letterbox
- TV format "16:9": Always 16:9 or Automatically

#### TV-Scart-Output

Select the type of video signal at the TV Scart socket here. Select the signal that your TV set can process.

- FBAS – Color Video Baseband Signal
- RGB – Red/Green/Blue signal (not currently available) or
- Y/C – S-Video signal (luminance/chrominance)

#### HDMI/YUV Format

Select here the video resolution that is to be used on your TV. Either

- 1080i (resolution 1920 x 1080, half-screen images)
- 576p (resolution 720 x 576, full-screen images) or
- 720p (resolution 1280 x 720, full-screen images)

#### Show 4:3 event

Select here the type of screen display for 4:3 programmes on a 16:9 TV:

- normal (Pillarbox)
- stretched (Fullscreen)
- zoom in (Pan & Scan)

#### Audio format via HDMI

Select here the type of audio signal that is to be output over the HDMI interface. Select the signal that your TV set can process.

- Decoded PCM
- S/PDIF format



Press the  (green) button to move to the next menu.

# FIRST INSTALLATION

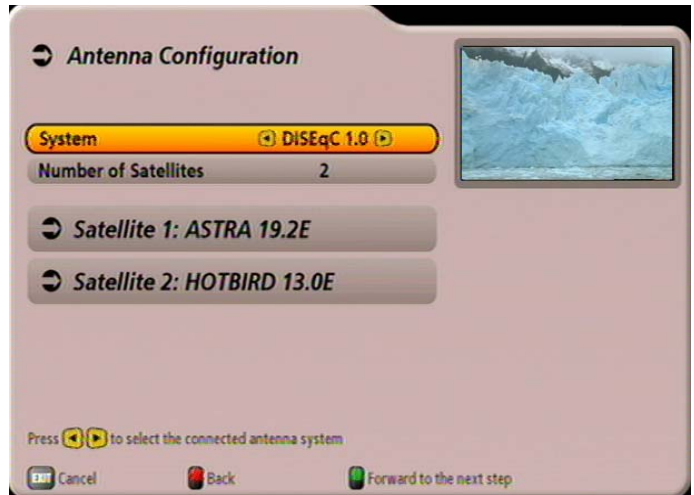
The following display appears:



## System

Select the setting here to match your reception system using the   buttons. You have the following options:

- DiSEqC™1.0
- One Cable
- LNB only

If your reception system supports DiSEqC™, in “System” select “DiSEqC™1.0” (is used for switch-over from one received satellite to another). If your reception system does not support DiSEqC™, select the setting “LNB only”. If your receiver is connected to a single-cable system, select “One Cable”.

Press the  button to move to the next menu item.

Continue with the relevant section of “First Installation”.



**When selecting the satellite(s), make sure that your reception position is aligned to the desired satellite(s)!**

# FIRST INSTALLATION: DiSEqC™1.0

## Number of Satellites

Use the ◀▶ buttons to select how many satellites (max. 4) you would like to receive with your reception system. The following display appears (example):

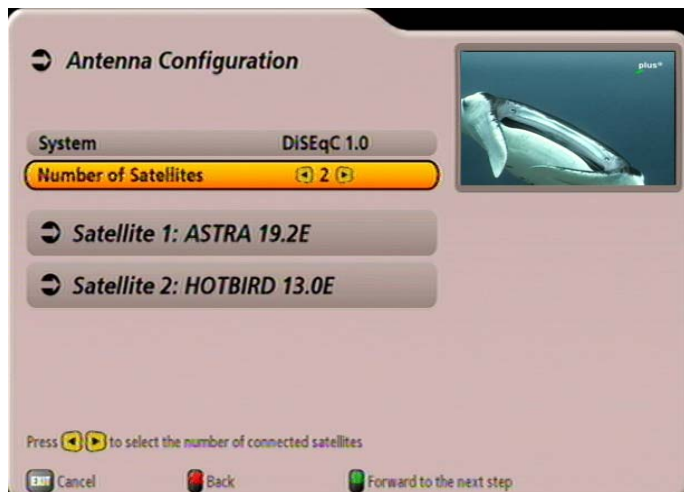

Use the ▲▼ buttons to select the first satellite slot. Press OK to open the menu for the satellite settings. The following display appears (example):

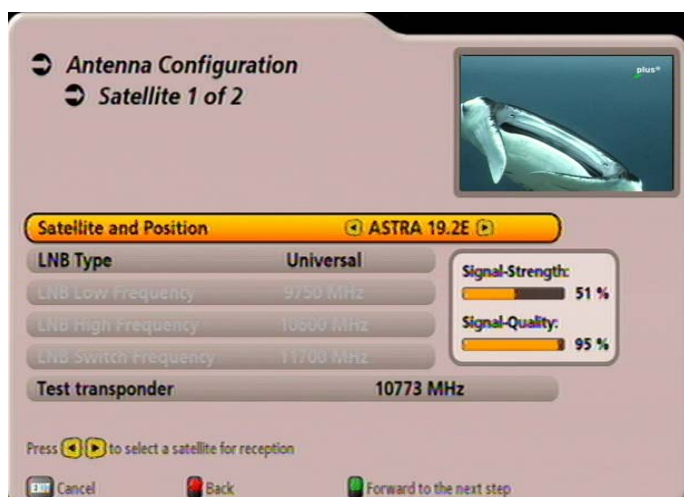

## Satellite and Position

Use the ◀▶ buttons to set the desired satellite (selection from 17 pre-programmed options).

# FIRST INSTALLATION: DiSEqC™1.0

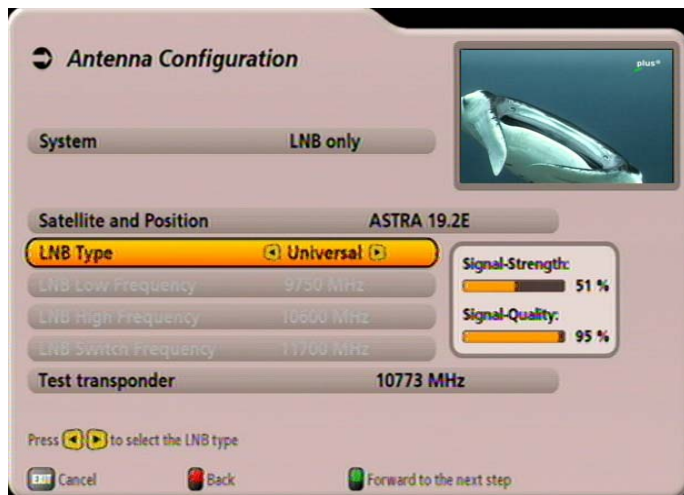

## LNB Type

Here use the **[Left] [Right]** buttons to select the LNB type used in your system. The choice is between “Universal” and “user-defined”.

Universal:

No further input is required, since all necessary frequency ranges are covered by a universal LNB.

user-defined:

If you choose not to use a universal LNB, you must here set the frequency ranges for which your LNB was configured.

Use the **[Up] [Down]** buttons to select the frequency range to be changed (low, high or limit frequency).

Use the **[Left] [Right]** buttons or the number buttons to set the exact frequency for which your LNB was configured.

## Test transponder

To check whether the settings that you have made are correct, use the **[Up] [Down]** buttons to move to the “Test transponder” field. Use the **[Left] [Right]** buttons to select the various transponders. If your settings are correct, you will see at the top right of the screen the live signal of a channel for the currently selected transponder.

**If you are not receiving a signal, check your settings again and if necessary call for expert help.**

You have now completed all settings for the first satellite. Press the **[EXIT]** button to return to the “Antenna Configuration Menu” and perform the settings in the same way for the remaining satellites.

When you have finished configuring the satellite press **[PIP]** (green). The receiver then automatically opens the menu for the channel search. Continue with the section (Execute channel search).



# FIRST INSTALLATION: LNB ONLY

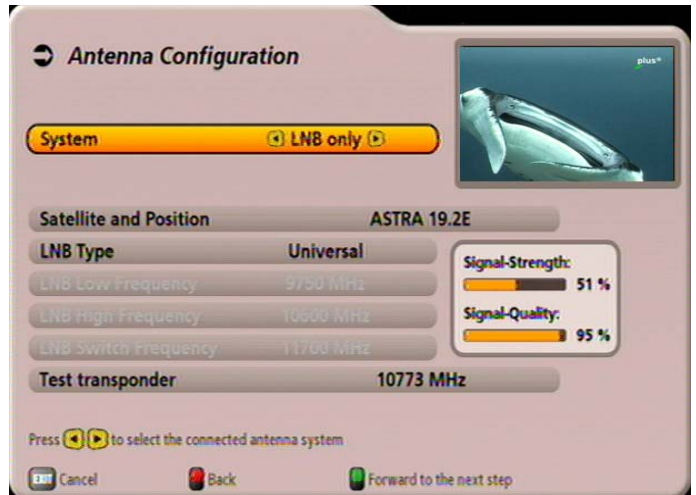

## Satellite and Position

Use the buttons to select the desired satellite whose signal is to be received by the tuner.

When you have selected your desired satellite, use the buttons to switch to the selection of the "LNB Type".

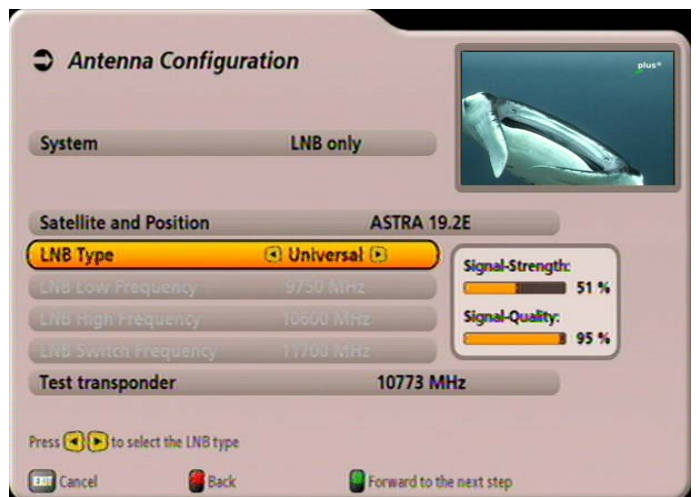

## LNB Type

Here use the buttons to select the LNB type used in your system. The choice is between "Universal" and "user-defined".

Universal:



No further input is required, since all necessary frequency ranges are covered by a universal LNB.

## FIRST INSTALLATION: LNB ONLY



user-defined:



If you choose not to use a universal LNB, you must here set the frequency ranges for which your LNB was configured.

Use the   buttons to select the frequency range to be changed (low, high or limit frequency).

Use the   buttons or the number buttons to set the exact frequency for which your LNB was configured.

### Test transponder



To check whether the settings that you have made are correct, use the   buttons to move to the

“Test transponder” field. Use the   buttons to select the various transponders. If your settings are correct, you will see at the top right of the screen the live signal of a channel for the currently selected transponder.

**If you are not receiving a signal, check your settings again and if necessary call for expert help.**

When you have finished configuring the satellite, press the  (green) button. The receiver then automatically opens the menu for the channel search. Continue with the section (Execute channel search).



# FIRST INSTALLATION: One Cable

Use the   buttons here to select “One Cable” as the “System”. Press the  button to move to the next menu item. The following display appears:

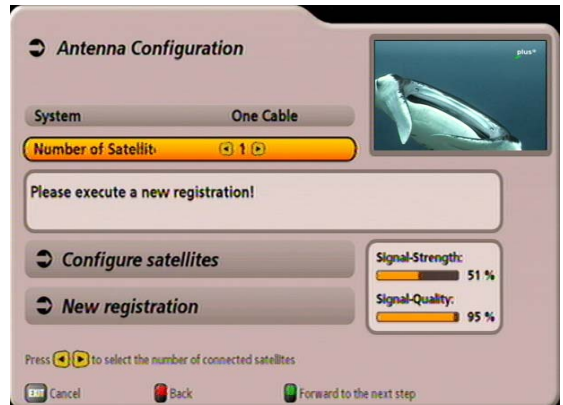
 The various options for a single-cable system with Kathrein components are summarised at the end of this manual in the “Technical Appendix” section under “Examples of Single-Cable Systems”.



## Number of Satellites

Use the   buttons to select how many satellites (max. 2) you would like to receive with your reception system. Press the  button to move to the next menu item.

## Configure satellites



Press the  button to open the menu. The following display appears:



## Satellite and Position

Use the   buttons to select the first satellite (satellite 1 of 2, depending on the setting) as shown on the screen.

## LNB Type

Here use the   buttons to select the LNB type used in your system. The choice is between “Universal”, “Wideband” and “user-defined”.

**If in your reception system you use a single-cable LNB (e.g. UAS 481 from Kathrein), please select here the setting “Wideband”. If you use a single-cable matrix (EXU 908) or a single-cable switching matrix (EXR 551 or EXR 552) from Kathrein, the LNB you use must be a “Universal LNB”!**

## FIRST INSTALLATION: One Cable

Universal:



No further input is required, since all necessary frequency ranges are covered by a universal LNB.



Wideband:

No further input is necessary, since all frequency ranges are set by the Wideband LNB.

user-defined:

If you are not using a Universal or a Wideband system, you must set the frequencies here. You can find the necessary information in the documentation supplied with your system.



Use the   buttons to select the frequency range to be changed (low, high or limit frequency).

Use the   buttons or the number buttons to set the exact frequency for which your LNB was configured.

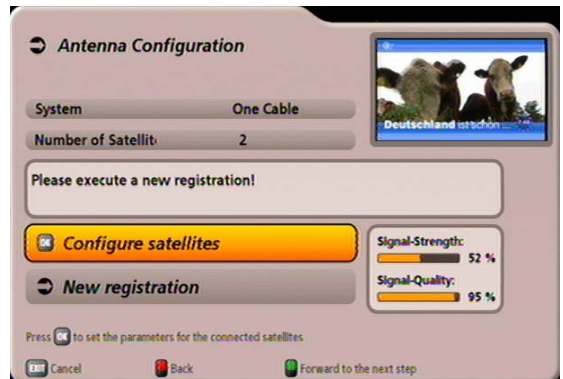

When you have completed all setting for the currently selected satellite, press the  button. If you have selected more than one satellite, repeat the previous “Satellite and Position” and “LNB Type” processes for the number of satellites you selected.

When you have completed the settings for all the satellites, the following display appears:



Use the  button to select the next menu item “New registration” and press the  button. The following display appears:



Use the   buttons to select the type of installation you want and confirm with the  button. For clarity, we have split further details into two sections.

Firstly we give details of “Automatic” installation, then details of “Manual” installation.



## FIRST INSTALLATION: Single-cable system (automatic)

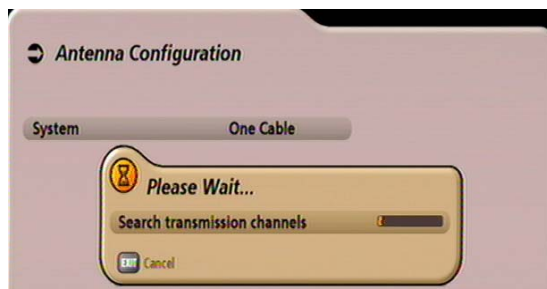

If one or more receivers are already present on the system and an additional receiver is to be connected, when assigning the transmission frequency for the new receiver make sure that no transmission frequencies are duplicated. No frequency can be used by more than one receiver.

The receiver searches for the transmission channels on your single-cable system and shows in the next display the available transmission channels.



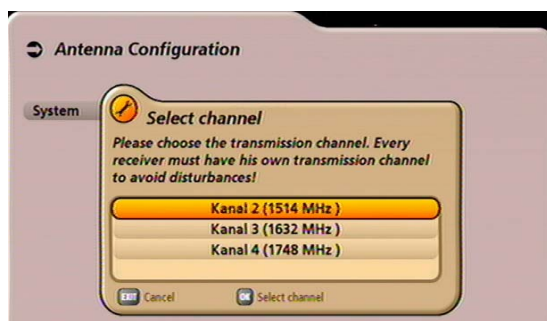

Use the   buttons to select the transmission channel you want and confirm the selection with the  button.



**No frequency can be used by more than one receiver. The receivers would interfere with each other.**

The receiver now reads the existing system data for your single-cable system and configures itself.



The receiver has been successfully registered on your single-cable system. Confirm the display with the  button. Now press the  (green) button. The receiver will automatically display the menu for the channel search. Continue with the section (Execute channel search).



If no connection to the single-cable system could be established, you will receive the message "Registration was abortive!". Check your settings and if necessary call for expert help.



## FIRST INSTALLATION: Single-cable system (manual)

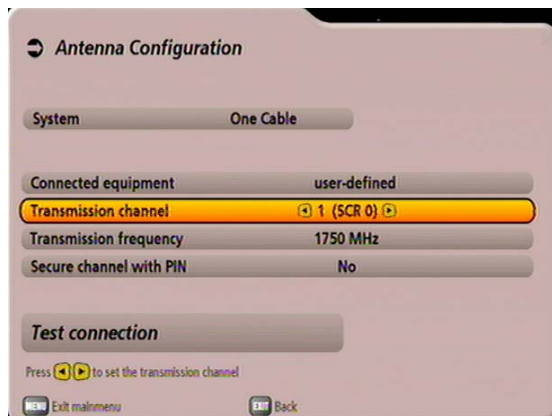

If one or more receivers are already present on the system and an additional receiver is to be connected, you must assign the new receiver a transmission frequency that is not already in use (otherwise the receivers will interfere with each other). Depending on the system to which they are connected, a maximum of four or eight receivers may be connected to a single-cable system (a twin receiver counts as two receivers).



### Connected equipment

Use the   buttons to select the type of system to which they are connected or the single-cable system components fitted (refer to the manuals, instructions and notes for the system and the system components). Available options:

- user-defined
- KATHREIN UAS 481 (single-cable feed system, max. four receivers)
- KATHREIN EXR 551 (single-cable switching matrix, max. four receivers applies also for EXR 501)
- KATHREIN EXR 552 (single-cable switching matrix, max. four receivers)
- KATHREIN EXU 908 (single-cable matrix, max. eight receivers)
- EXR 4 subscriber (for future Kathrein single-cable (switching) matrices, max. four receivers)
- EXR 8 subscriber (for future Kathrein single-cable (switching) matrices, max. eight receivers)

### Selection “user-defined”

#### Transmission channel

Use the   buttons to select a free available transmission channel.

#### Transmission frequency

Use the number buttons to input the four-digit transmission frequency.





No frequency can be used by more than one receiver. The receivers would interfere with each other. You can find the necessary information (transmission frequencies) in the documentation supplied with your system.

## FIRST INSTALLATION: Single-cable system (manual)

### Secure channel with PIN

If your single-cable system allows the transmission frequency to be protected by entering a PIN, this is the menu for defining the PIN. No other receiver can then use that transmission frequency unless the PIN is input.

Select the setting “Yes” using the   buttons. A line with the text “Password PIN” is then displayed.





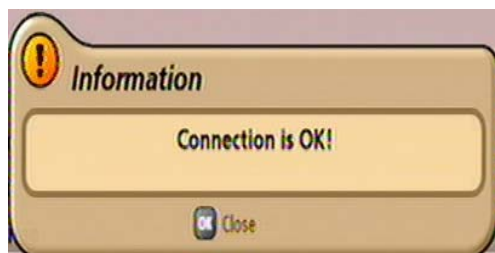

Press the   buttons to select this line. You can now use the number buttons to enter a PIN (0-255).

### Test connection

When you have completed all the settings, press the   buttons to switch to the “Test connection”

selection field and press the  button. The receiver now tests whether a connection to the single-cable system can be established or not. As soon as the receiver has established a connection to the single-cable system, you will see the following display:



Press the  button to acknowledge this display. Then press the  button. You will be asked whether you wish to save the changes. Use the   buttons to select “Yes, save changes” and confirm by pressing the  button. Now press the  (green) button.

The receiver will automatically display the menu for the channel search. Continue with the section (Execute channel search).

If no connection to the single-cable system could be established, the following display appears:



Check your settings (frequency and transmission channel) and if necessary call for expert help.

# FIRST INSTALLATION: Single-cable system (manual)



Selection "UAS 481" or "EXR 551"



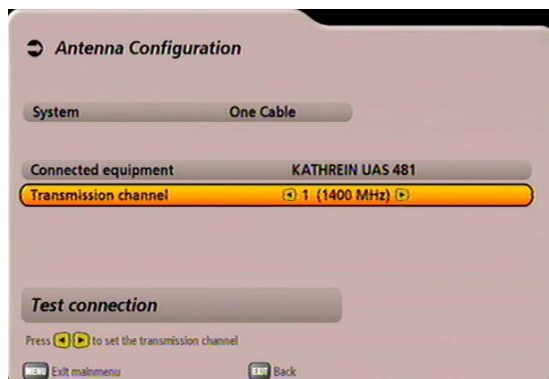

**When the UAS 481 single-cable feed system is being used, it is essential that the LNB is set to "Wideband"!**  
**When the EXR 551 single-cable switching matrix is being used, it is essential that the LNB is set to "Universal"!**









## Transmission channel

Use the   buttons to select a free available transmission channel. A maximum of four transmission channels are available (1400, 1516, 1632 and 1748 MHz).

## Test connection

When you have set a free transmission channel, press the   buttons to switch to the "Test connection" selection field and press the  button. The receiver now tests whether a connection to the single-cable system can be established or not. As soon as the receiver has established a connection to the single-cable system, you will see the following display:

Press the  button to acknowledge this display. Then press the  button. You will be asked whether you wish to save the changes. Use the   buttons to select "Yes, save changes" and confirm by pressing the  button. Now press the  (green) button.

The receiver will automatically display the menu for the channel search. Continue with the section (Execute channel search).

If no connection to the single-cable system could be established, the following display appears:



Check your settings and if necessary call for expert help.





# FIRST INSTALLATION: Single-cable system (manual)

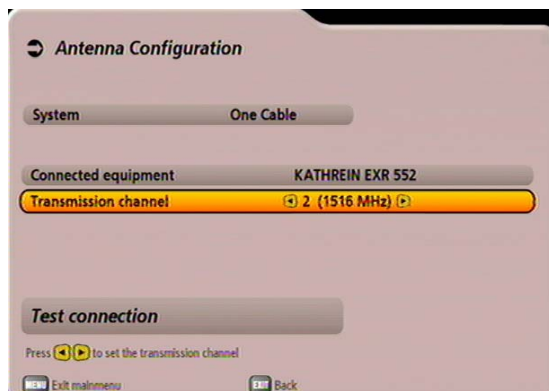
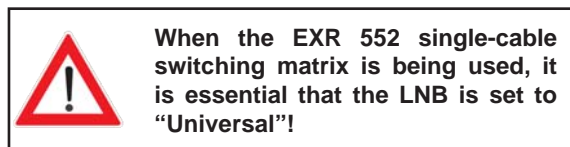

## Selection "EXR 552"









### Transmission channel

Use the   buttons to select a free available transmission channel. A maximum of two transmission channels are available (1400 and 1516 MHz).

### Test connection

When you have set a free transmission channel, press the   buttons to switch to the "Test connection" selection field and press the  button. The receiver now tests whether a connection to the single-cable system can be established or not. As soon as the receiver has established a connection to the single-cable system, you will see the following display:

Press the  button to acknowledge this display. Then press the  button. You will be asked whether you wish to save the changes. Use the   buttons to select "Yes, save changes" and confirm by pressing the  button. Now press the  (green) button.



The receiver will automatically display the menu for the channel search. Continue with the section (Execute channel search).

If no connection to the single-cable system could be established, the following display appears:





Check your settings and if necessary call for expert help.

# FIRST INSTALLATION: Single-cable system (manual)

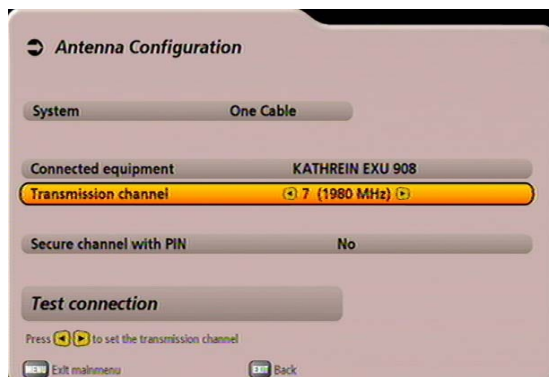
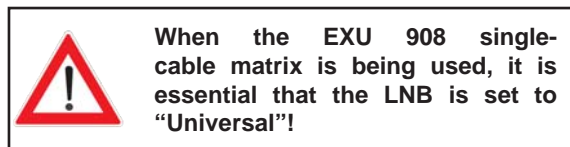
## Selection "EXU 908"





### Transmission channel

Use the   buttons to select a free available transmission channel. A maximum of eight transmission channels are available (1284, 1400, 1516, 1632, 1748, 1864, 1980 and 2096 MHz).



### Secure channel with PIN

The EXU 908 single-cable matrix allows the transmission frequency to be protected by inputting a PIN. No other receiver can then use that transmission frequency unless the PIN is input.

Select the setting "Yes" using the   buttons. A line with the text "Password PIN" is then displayed.

Press the   buttons to select this line. You can now use the number buttons to enter a PIN (0-255).

### Test connection

When you have set a free transmission channel, press the   buttons to switch to the "Test connection" selection field and press the  button. The receiver now tests whether a connection to the single-cable system can be established or not. As soon as the receiver has established a connection to the single-cable system, you will see the following display:

Press the  button to acknowledge this display.

Then press the  button. You will be asked whether you

wish to save the changes. Use the   buttons to select

"Yes, save changes" and confirm by pressing the  button.

Now press the  (green) button.

The receiver will automatically display the menu for the channel search. Continue with the section (Execute channel search).

If no connection to the single-cable system could be established, you will receive the message "Registration was abortive!".

Check your settings and if necessary call for expert help.



## FIRST INSTALLATION: Channel search



### Execute Channel search

Use the buttons to select (yes or no) whether you wish to start a channel search. It is not essential to start a channel search; instead you can use the factory pre-programmed channels. However the channels do change from time to time (e.g. their frequencies change), which the receiver does not automatically detect, and can then be found only by performing a channel search.

If you selected “No”, you can press the (green) button to skip directly to the next item of the first installation.

If you selected “Yes”, you can press the button to progress to the next selection item.

### Channel Search Mode

Use the buttons to select whether you wish to search for “free & scrambled”, “free channels only” or “scrambled only” channels.

**To view scrambled channels you need the appropriate CA (Conditional Access) module and a valid smart card together with a valid subscription to a pay TV provider.**

Press the button to move to the next selection item.

### Network Search

If you set the network search to “Off”, only the factory stored transponders of the satellites you previously selected will be searched for new and as yet unlisted channels.

If you set the network search to “On”, the transponder network enables additional transponders that have not yet been stored to be located. They are then stored and searched for new channels in the same way as the existing transponders.

Press the (green) button to start the channel search, or if you set channel search to “Off” you are guided straight to the next item in the first installation process.

When the search has been completed, you will see the following message (example):

# FIRST INSTALLATION: CHANNEL SEARCH

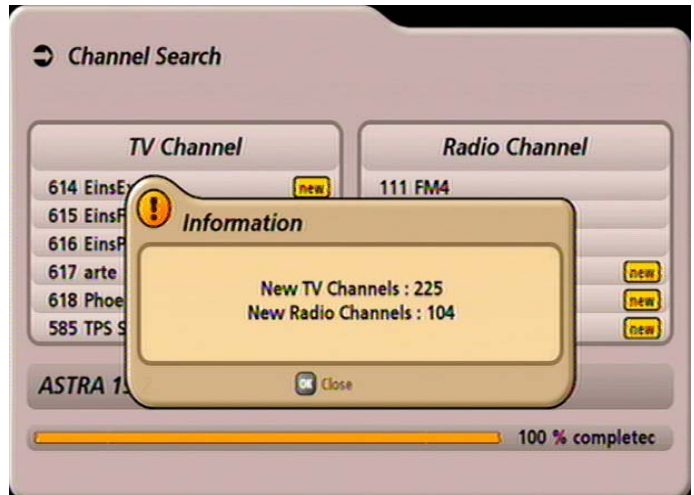

Press the **OK** button twice to save the new channel. You will then move on to the next step of the first installation; the following is displayed:

## Local time offset (UTC)

Use the **Left/Right** buttons to set the time zone variation from UTC (formerly GMT) (e.g. for Germany +1 hour).

Use the **Up/Down** buttons to switch to the "Automatic clock change" field. Use the

**Left/Right** buttons to select whether the receiver should automatically change over between summer and winter time. If "On" is selected, the receiver automatically sets itself to the right time. If you select the setting "Off", you must make the change to and from summer time yourself, using the "Summertime"



field displayed below. Press the **Left/Right** buttons to make the setting.

## update time on

Set the required type of time update using the **Left/Right** buttons. The following options are available:

- "Actual channel (Das Erste)" (the time information is taken from the channel "Das Erste" - you can change this setting later on the "Date and Time" menu) or
- "all channels" (the time information is always taken from the channel currently selected)

The time will be updated in future based on the variant you have set.

Press the **PP** (green) button to terminate the first installation.

# OPERATING INSTRUCTIONS

## MENU CONCEPT

The structure of the menu concept is based on logical operating sequences. The programme showing on the current selected channel always appears in the top right-hand corner of the screen.

**You will find detailed descriptions of the selected menu items in the relevant sections of the operating manual!**

**Note:** *The selected menus, sub-menus and positions, as well as the parameters to be set, are each highlighted in colour. The menus are self-explanatory.*

Pay attention to the bar at the bottom of the on-screen display. These provide information on what to do next.

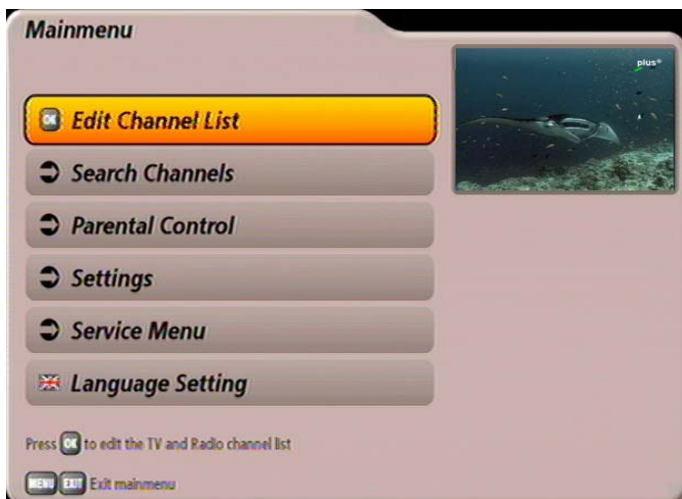

Press the **MENU** button to open the main menu and press the **▲▼** buttons to select the sub-menus.

Press the **OK** button to open the sub-menus. Press the **▲▼** buttons to select items within the sub-menus.

The settings under the various options are made either by pressing the **◀▶** buttons or using the number buttons. You can exit the main menu and sub-menus, and the various options, step-by-step by pressing the **EXIT** button (the settings/changes you made are saved). Press the **MENU** button to return directly from one of the menus to the TV picture (the settings/changes you made are saved).

# OPERATING INSTRUCTIONS

## MENU TREE

### Main menu

Open using the  button



# OPERATING INSTRUCTIONS

## ALPHANUMERIC ENTRIES

Use the keypad displayed (see figure to the right) for the entry of favourite names or search expressions by selecting the required numbers/digits using the number buttons. You can

choose between upper or lower case letters (MENU button). Use the number buttons to select the desired character. About two seconds after selection of the character, the cursor moves

automatically to the next position. The LEFT button allows you to delete your entry character by character.

When you have selected all the characters, press the

OK button to save your entry or start a search to find the desired expression.



## LANGUAGE SELECTION - OSD

The language for the on-screen display is set as follows:

MENU → ▲ ▼ → Language Setting → OK → ▲ ▼ → English → OK

Available options: German, English, French, Italian, Spanish, Czech, Dutch, Polish, Turkish and Russian.

After you have performed the settings, press the MENU or the EXIT button to exit the main menu. You will then return to the TV picture.

# ON-SCREEN DISPLAYS (OSD)

## CHANNEL OSDS

### TV CHANNEL OSD

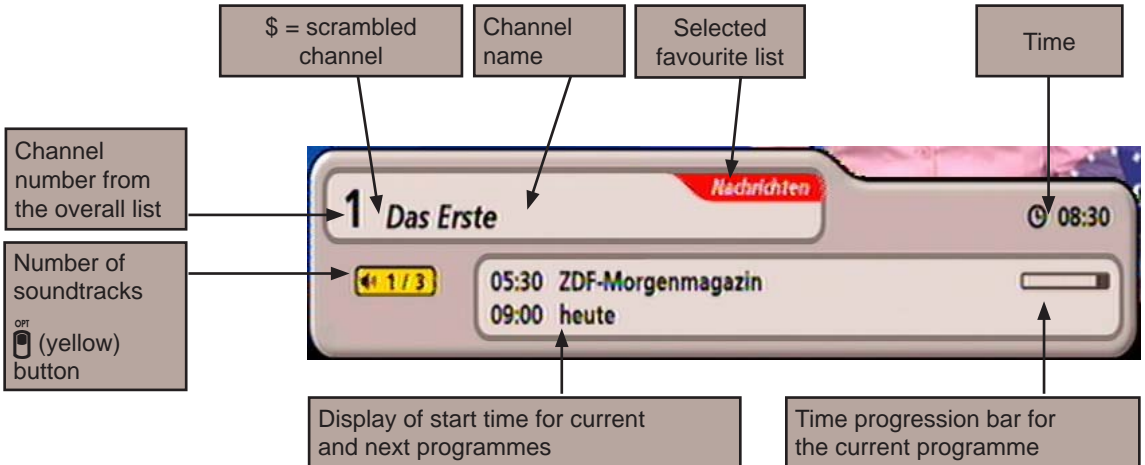

The channel OSD is displayed for a few seconds each time the channel is changed (this feature can be changed on the "Settings", "Customize Screen Menu" menu) or displayed continuously by pressing the **i** button.

### RADIO CHANNEL OSD

The OSD for the current radio channel has the same layout.

## PROGRAMME INFORMATION

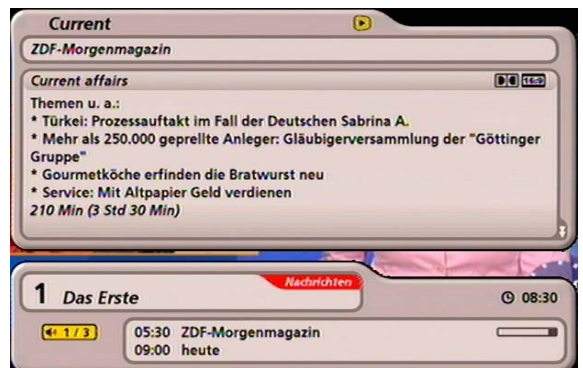

Press the **i** button twice to view information on the current channel, if transmitted by the channel provider. Use the **▲▼** buttons to scroll through the pages. By pressing the **◀▶** buttons you can obtain information on the programmes to come on the current channel. Press the **i** or **EXIT** button to exit the display.





## ON-SCREEN DISPLAYS (OSD)

### OPENING MEDIA SELECTION (TV, RADIO ...)

You can open the media selection by pressing the <sup>TVR</sup> (blue) button. The following display appears:

You have the following selection options:



- TV mode
- Radio mode

The selection is made using the   buttons and confirmed with the  button.









**TV mode:** Receiver returns from the radio mode to the TV mode

**Radio mode:** The receiver switches to radio mode





Confirm the change by pressing the  button, or cancel the procedure by pressing the  button or the <sup>TVR</sup> (blue) button to exit the display again.

### OPENING OPTIONS CHANNEL

If the channel OSD contains the following icon , this is a portal channel. Press the <sup>OPT</sup> (yellow) button to display the channels available on this portal (such as matches on a specific day of play). In this example three “sub-channels” are available for selection within this portal channel. Select the channel using the   and  buttons. You can also however select the sub-channels of a portal channel directly using the   buttons, without having previously pressed the <sup>OPT</sup> (yellow) button.

## ON-SCREEN DISPLAYS (OSD)

### OPTION SELECTION

Press the  (yellow) button once (twice for portal channels) to view further soundtrack selection options, if these are transmitted by the channel provider. Use the   buttons to scroll through the available selection options. Press the  (yellow) button again, or press the  button to exit this display again.



### ERROR MESSAGE

"No or bad signal" indicates that an error has occurred in the reception system or in the receiver settings, or that the transponder is not transmitting.

Check the Sat IF connection and the LNB configuration. If you have changed settings, compare them against the basic settings (provided you had made a note of them as suggested).

### CHANNEL LIST - TV/RADIO

Also note the bars at the bottom of the on-screen display! These provide information on what to do next.



Press the  button to open the channel list.

When you open this list the channel list selection / sort order is displayed from where you selected the last channel.

At the top left you will see the selected channel list (TV Channel or Radio Channel) displayed.









Press the  (blue) button to switch between the TV and radio channel lists.

Underneath you can see the channel list with the sort order you selected.

The channel list can display channels sorted by various selection and sorting criteria.

# ON-SCREEN DISPLAYS (OSD)

## Selection and sorting options:

- Press the  (red) button to open the favourite list selection. The   buttons allow you to scroll through the existing favourite lists.
- Press the  (green) button to return to the overall list (all satellites). Use the   buttons to choose between the received satellites (display all channels from a satellite) and the list of "New channels" (provided by channel search).
- Press the  (yellow) button to see an alphabetic list. This list displays all the channels sorted alphabetically, or the ones beginning with the selected initial letter. Use the   buttons to make the selection.

## Search function:





- Press the  button to start the search. Use the number buttons to enter the desired search expression for the channel that is sought (see also "Operating instructions", "Alphanumeric entries").

Press the  button to start the search (see screenshot below for an example of a search result).

Press the  button to view the following additional items of information on a channel (see example screenshot at right):

- Signal strength
- Signal quality
- Transmitting satellite
- Frequency (MHz)
- Polarisation
- Symbol rate



Use the cursor buttons (   ) to select the desired channel in the various channel list views.

Confirm the selection of the desired channel by pressing the  button. You will now hear and see the currently selected channel in the small window at the top right. To exit the channel list and return

to the TV picture, press the  button again, or press the  button.

# EPG - ELECTRONIC PROGRAMME GUIDE

## OPENING THE EPG



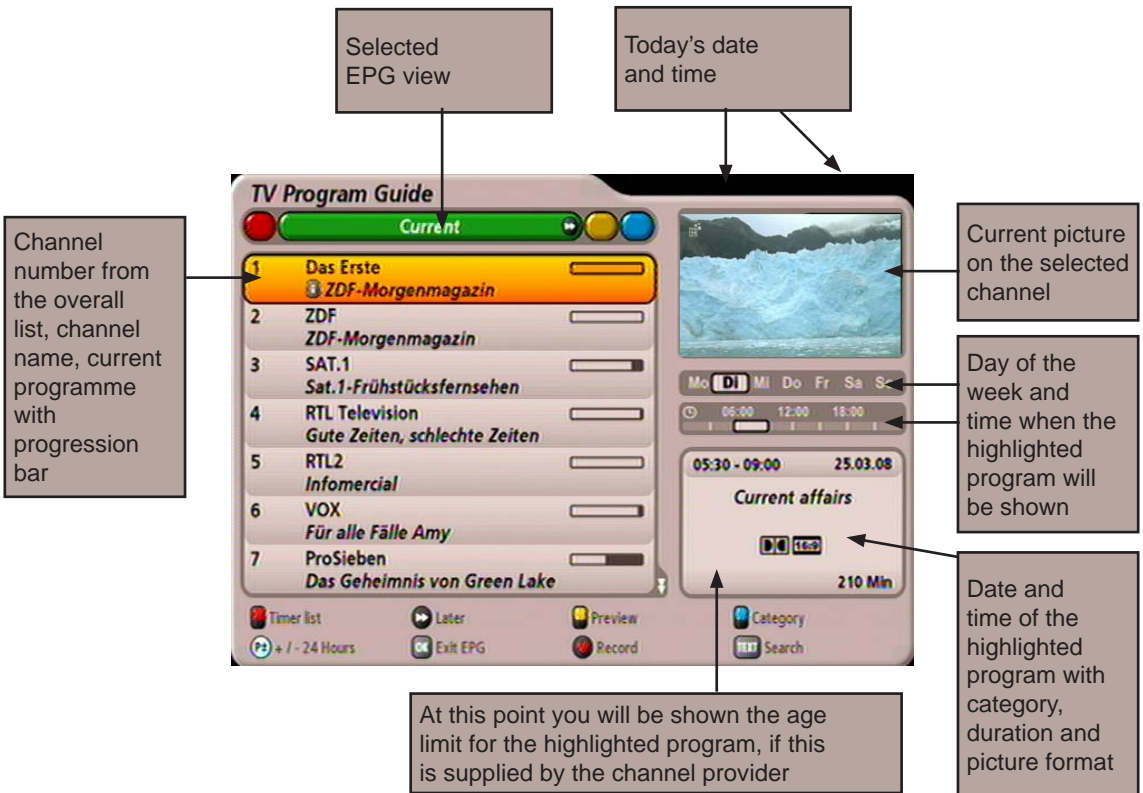







The EPG is opened by pressing the  button. Each time the EPG is opened, you will automatically be shown the “Current” view, irrespective of which view you were shown the last time you left the EPG. The following display appears (example):









**Note:** *If you selected a favourite list before opening the EPG, you will see in the EPG only the data for the channels that are included in this favourite list. Press the  button again to display the EPG for all channels.*

# EPG - ELECTRONIC PROGRAMME GUIDE

## Selection options:

-  (red) button      Open the timer list (display of all pre-programmed recordings)
-  button      Jump the “Current” view forwards by 15 minutes
-  (yellow) button      Open a preview of the currently highlighted channel
-  (blue) button      Open the category selection (sorting the programs by categories such as movies, sport, series ...)
-  button      (P+) jump forwards 24 hours in the EPG, (P-) jump backwards 24 hours in the EPG (e.g. in “Current” and in “Preview” view)
-  button      Select the currently highlighted channel in all views. Pressing the  button or the  button again closes the EPG and the selected channel is shown on the TV screen
-  (red dot) button      Add a programme to the recording settings
-  button      Search for a particular programme or programme content (enter the search expression using the number buttons on the remote control, see also the section “Operating instructions”, “Alphanumeric entries”)
-  button      Show, if present, further information on the selected programme

Navigation within each EPG view is always performed using the cursor buttons ().

The  buttons allow you to select individual channels/programs, and the  buttons allow you to scroll from page to page of the currently selected list.

Pressing the  or the  button exits the EPG again and returns to the TV picture.







**You will see information on the current or next following programmes in the EPG only if it is supplied by the channel provider. If no EPG data are available the receiver, instead of showing information on the current programme, shows the message “No data available”.**

## “CURRENT” VIEW

The “Current” view can be opened at any time in the EPG by pressing the  (green) button. This view is automatically displayed every time the EPG is started (see screenshot “Opening EPG”).

In the “Current” view you see all channels displayed in the order of the overall channel list. Provided that EPG data has been supplied by the channel provider, the receiver shows for each channel the current programme being shown, with start time, finish time, and progression bar.

You can use the cursor buttons () or the number buttons to select the desired channel and, if available, you can use the  button to open further information on the desired programme. The

## EPG - ELECTRONIC PROGRAMME GUIDE

▶ button allows you to look ahead in 15 minute steps to future programmes on the channels (press the ◀ button to return to the current time).

If you wish to view the program currently being shown on a channel, you need not to exit the EPG, just select the desired channel and press the **OK** button. At the top right of the screen you will see the current TV picture for the selected channel. The picture however only appears once the **OK** button has been pressed. Previously what you saw was the picture of the old channel that had previously been selected, even though the EPG was no longer set to that channel.

### “PREVIEW” VIEW (PROGRAMME MAGAZINE)

The “Preview” view (programme magazine) can be opened at any time in EPG by pressing the **OFF** (yellow) button.

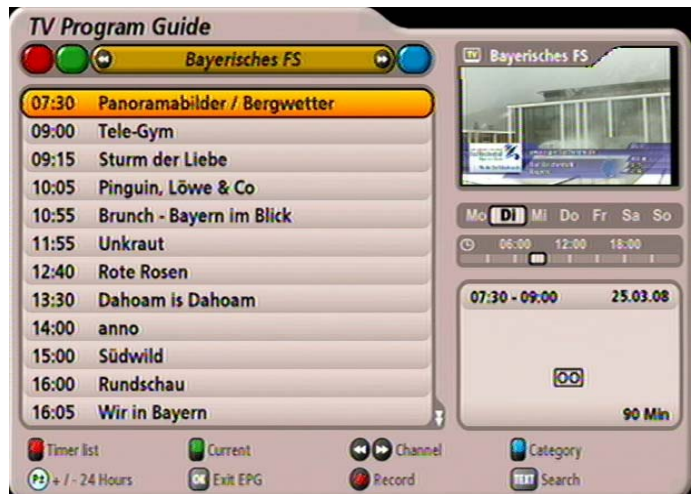

Also note the bars at the bottom of the on-screen display! These provide information on what to do next.

In the “Preview” view you will see all the programmes that will be shown in the previous “Current” list of selected channels. Provided that EPG data has been supplied by the channel provider, the receiver displays the programmes that will be shown on the selected channel for several days in advance.

You can use the cursor buttons (▲▼◀▶) to select the desired programme and, if available, you can use the **i** button to open further information on the desired programme.

You can use the ◀▶ buttons to scroll through the channels in the order of the overall channel list (the channels can also be selected by entering digits with the number buttons); you remain however in “Preview” view.

The ⏮ button allows you to scroll backwards and forwards a day at a time.

Using the ● (red dot) button you can copy the selected programme to the recording settings (see “Recording” section).

# EPG - ELECTRONIC PROGRAMME GUIDE





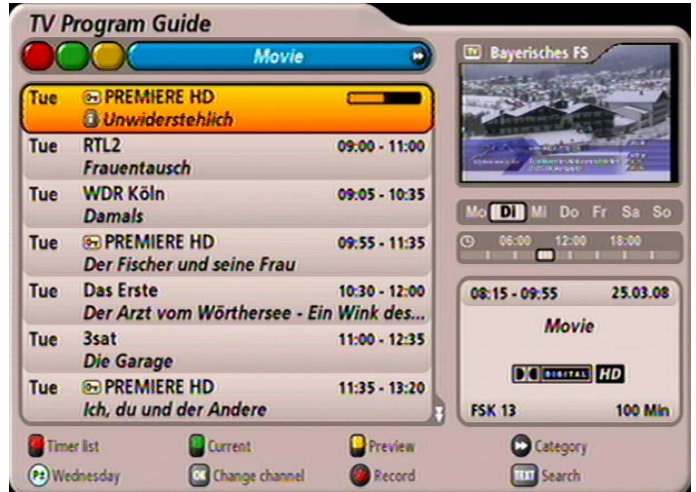

## CATEGORIES VIEW

The “Categories” view can be opened at any time in EPG by pressing the  (blue) button.



In the “Categories” view you can see all programmes sorted by category and starting time. The following categories are available for selection: Movies, Series, Sport, Program for kids, Entertainment, Current affairs, Reportage, Art & Culture, Education, Music, Leisure and Adult.

Programmes can be assigned to the above categories only if the EPG data has been supplied by the channel provider.

Select the required category using the   buttons. You can then use the cursor buttons (, , , ) to select the desired category and, if available, you can use the  button within each category to open further information on the desired programme.

The  button allows you to scroll backwards and forwards a day at a time.

Using the  (red dot) button you can copy the selected program to the recording settings (see “Recording” section).

# EPG - ELECTRONIC PROGRAMME GUIDE

## SEARCH FUNCTION

The search function can be opened at any time in EPG by pressing the **TEXT** button.



The search function allows you to search for programmes based on their additional information or their name. Use the number buttons to enter the desired search expression (see also “Operating Instructions” “Alphanumeric Entries”).

When you have entered the desired search expression, press the **OK** button to start the search.

You can then use the cursor buttons (**▲▼◀▶**) to select the desired programme from the search result and, if available, you can use the **i** button to open further information on the desired programme.



Using the **●** (red dot) button you can copy the selected programme to the recording settings (see “Recording” section).



# EPG - ELECTRONIC PROGRAMME GUIDE

## ADDITIONAL INFORMATION (i BUTTON)

The additional information can always be opened by pressing the **i** button whenever the “i symbol” appears in front of the programme name (see screenshot on the right). First however the channel must be selected. The following display appears (example):



The additional information available for a programme is displayed in its own window. By pressing the **v** button, if available, you can open further additional information on the selected programme.

The **◀▶** buttons enable you to display the additional information for the preceding or following programmes in the order of the previously selected list (see header). This feature always assumes that the data has been supplied by the channel provider.

Using the **●** (red dot) button you can copy the selected programme to the recording settings (see “Recording” section).

Press the **i** or the **EXIT** button to exit the additional information.

## REMINDER FUNCTION (CHANGE OVER TO PROGRAMME)

If you wish to be reminded at the start of a programme, you can activate the reminder function for the desired programme. The reminder function is set up in exactly the same way as programming a recording. The only difference is that in the “Target” line the entry must be “Reminder”. Select the desired settings for your reminder (see “Recording (timer)” for the setting options) and then confirm the setting of the

reminder function by pressing the **OK** button. The programme is marked in the Programme Guide with a green dot and the receiver will automatically switch over to the pre-selected channel at the start of the programme.

# EPG - ELECTRONIC PROGRAMME GUIDE

## RECORDING (TIMER)

The  (red dot) button allows you to set up a programme at any time for recording on an external recorder.

The programme to be recorded can be selected in any of the EPG views, provided the  (red dot) button appears at the bottom of the screen display.



### Programme present in the EPG:

Select the desired programme and press the  (red dot) button. The following display appears (see example picture below):



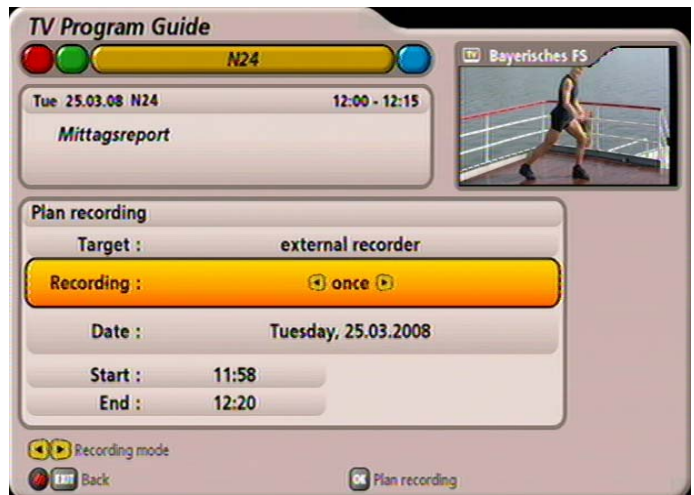
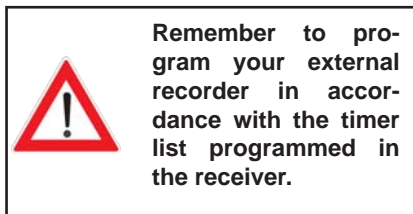

### Programme not present in the EPG:

Select any programme on the channel on which the desired programme is to be transmitted at a later time and press the  (red dot) button (starting and finishing times together with the recording date must be input manually). The following display appears (example):





Use the   buttons to select the desired recording mode. The following recording mode options are available:





- **once:** The recording will be performed once only
- **daily:** The recording will be performed daily at a time specified by you
- **weekly:** The recording will be performed once a week on the same day and at the same time
- **user-defined:** The recording will be performed on days specified by you at times specified by you
- **Series recording:** The selected programme will be set up by the EPG for recording every time it is transmitted (may even be on different channels). This function does however require a daily update of the EPG data (the data are updated automatically when switching off into stand-by mode).





Use the cursor buttons (   ) to select the further items and use the number buttons to complete the settings. When all settings have been made, press the  button to save the recording settings. You can view the scheduled recordings in the timer list view of the EPG (see section "Timer list").





# EPG - ELECTRONIC PROGRAMME GUIDE

## RECORDING ONCE ONLY

Use the   buttons to select the recording mode “once” (see screenshot “Recording (timer)” section).



Use the   buttons to switch to the selection field “Date” and use the   buttons to select the desired recording day.





Use the   buttons to switch to the selection field “Start” and use the   buttons or the number buttons to select the desired recording start time.





Use the   buttons to switch to the selection field “End” and use the   buttons or the number buttons to select the desired recording end time.

When all settings have been made, press the  button to save the recording settings. You can view the scheduled recording in the timer list view of the EPG (see section “Timer list”).

## RECORDING DAILY

Use the   buttons to select the recording mode “daily” (see screenshot below).

Use the   buttons to switch to the selection field “Start” and use the   buttons or the number buttons to select the desired recording start time.

Use the   buttons to switch to the selection field “End” and use the   buttons or the number buttons to select the desired recording end time.



When all settings have been made, press the  button to save the recording settings. You can view the scheduled recording in the timer list view of the EPG (see section “Timer list”).





# EPG - ELECTRONIC PROGRAMME GUIDE





## RECORDING WEEKLY



Remember that the day of the week for the desired programme is copied to the timer list and you can make no further manual corrections to it! Therefore before pressing the  (red dot) button, select the programme on the day of the week that in future you will wish to make the weekly recording.

Use the   buttons to select the recording mode “weekly” (see screenshot below).

Use the   buttons to switch to the selection field “Start” and use the   buttons or the number buttons to select the desired recording start time.







Use the   buttons to switch to the selection field “End” and use the   buttons or the number buttons to select the desired recording end time.







When all settings have been made, press the  button to save the recording settings. You can view the scheduled recording in the timer list view of the EPG (see section “Timer list”).





## RECORD USER-DEFINED

Use the   buttons to select the recording mode “user-defined” (see screenshot below).

Use the   buttons to switch to the selection field “Day” and use the   buttons to select the required day for the recording. Press the  button to fix the selection (the day will be shown in red letters). If necessary the receiver will suggest some days to you; you can accept these suggestions or deactivate them again using the cursor buttons and pressing the  button once.

Use the   buttons to switch to the selection field “Start” and use the   buttons or the number buttons to select the desired recording start time.

## EPG - ELECTRONIC PROGRAMME GUIDE

Use the   buttons to switch to the selection field "End" and use the   buttons or the number buttons to select the desired recording end time.





When all settings have been made, press the  button to save the recording settings. You can view the scheduled recording in the timer list view of the EPG (see section "Timer list").

### SERIES RECORDING



**Series recording depends on the EPG data being kept up to date at all times. The receiver automatically updates the EPG data when the unit is switched off by pressing the  button. Updating is important because it enables the receiver to recognise for purposes of recording any changes to scheduled transmission times of the series, provided these were incorporated in the EPG data supplied by the channel provider in advance of the latest EPG update.**

Use the   buttons to select the recording mode "Series recording".

In series recording the start and finish of recording are taken automatically by the receiver from the EPG data. You can specify only a single value for the lead-in and run-on time to be sure to record the complete programme even if transmission times may vary slightly. The lead-in and run-out time is set using the   buttons or the number buttons.

When all settings have been made, press the  button to save the recording settings. You can view the scheduled recordings in the timer list view of the EPG (see section "Timer list").



# EPG - ELECTRONIC PROGRAMME GUIDE



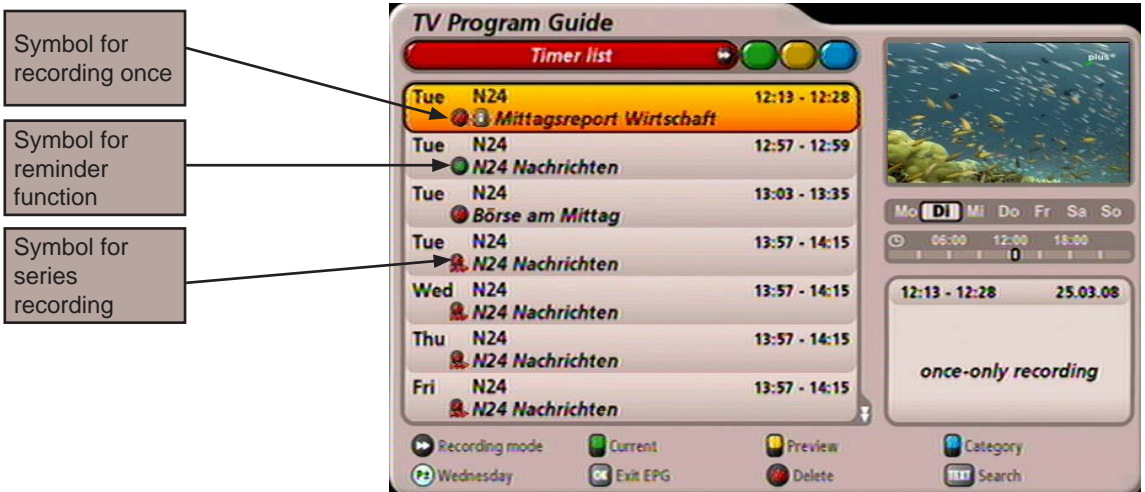

## TIMER LIST VIEW

The "Timer list" view can be opened at any time in EPG by pressing the  (red) button.



The timer list view shows you all the recordings that are scheduled.

The   buttons allow the recordings to be sorted into "once" or "repeated" recordings.

The cursor buttons (, , , ) allow you to select a recording. The  button allows you to switch to the channel on which the recording is scheduled.

The  (red dot) button allows you to delete a recording that had been scheduled. If this is a series recording you will additionally be asked whether you wish to cancel the recording of only one episode or whether you wish to record no further episodes of this series (see screenshot).

Selection is performed using the ,  buttons and is confirmed using the  button.



The  button allows you to skip backwards and forwards through the future scheduled recordings, a day at a time.

## COMMON INTERFACE

### IMPORTANT INFORMATION

Always follow the operating instructions from your pay TV provider and the instructions supplied with the Smartcard and the CA module!

Smartcards and CA module are not included with this product!

The cards and modules are issued by the respective pay TV providers, and contain the subscriber data and details of the channels for which the subscriber has paid. These channels are always scrambled.

Contact the pay TV provider if you are interested in subscribing to a particular pay TV channel.

You are responsible for the use of the Smartcard in the CA!

The Smartcard sold by the pay TV provider, specific to a particular encryption technology, is inserted into the CA module.

Store your card and PIN code securely when not in use!



### INSERTING THE SMARTCARD AND THE CA MODULE

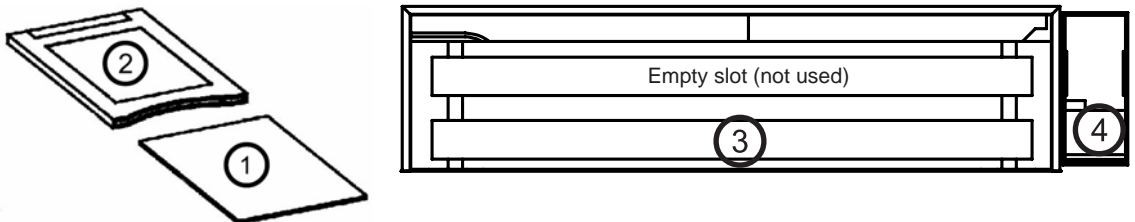

The Common Interface (CI) (3) of the UFS 902 is suitable for the use of one CA (Conditional Access) module. This CI slot is on the left on the front behind the flap.

The CA module (2) draws in the Smartcard (1) (chip contacts pointing downwards and towards socket strip) which it then inserts into the CI slot (3).

The Smartcard should be inserted into the CA module without exerting excessive force. This also applies to inserting the CA module into the CI slot.

Do not use without excessive force, and follow the instructions supplied with the Smartcard and the CA module.

To remove the module, press the relevant eject button (4).

## COMMON INTERFACE

You can find out which Conditional Access module is in the CI slot on the UFS 902 and which Smartcard is in which CA module from the “Mainmenu” under “Settings”, and the “Common Interface” menu.

Confirmation is by pressing the  button.

Press the  button. You will then see the menu generated by the CA module.

**The screenshots below depend on the specific module and card, and so are only intended as examples:**



From this menu, your card and your PIN code allow you to access various channels from your pay TV provider.

“CryptoWorks” has been selected as an example here. The details can be different for each CA module. Always follow the instructions supplied by your pay TV provider!

**Note:** *The module displays may be shown in English, even if you have selected German as the menu language, because the menu is generated directly by the module!*



Information for Conax, SECA, Viaccess and CryptoWorks users:

Note that with monthly activation intervals, the channel providers have different procedures for activating pay TV cards. Activation may therefore be a few days before or after the beginning of a new month. During this activation period, the CA module and card must be in the slot, and the receiver must be turned on a set to the booked pay TV channel. Follow the instructions from the pay TV provider.

If your pay TV card is then still not enabled, we recommend you briefly withdraw the CA module with the card out of the slot, with the receiver switched on, and then re-insert it.

**This information has nothing to do with the properties of the unit; it is merely intended to assist you.**

The various items can be selected using the   buttons and opened using the  button. Press the

 button to exit the menu.



# TELETEXT







When you press the  button, the receiver processes the broadcast Videotext/Teletext service, if available, for your TV set to display, even when the signal is encrypted.

During the search, the page which is being searched for is displayed in the top left-hand corner with the time and date displayed at the top right.







When the search is finished, the teletext broadcast by the relevant program provider appears:

You have several options for opening the desired pages:

- Enter using the number buttons
- Scroll through using the   buttons
- Select the options shown at the bottom end by pressing the related colour button  (red),  (green),  (yellow), and  (blue)

Press the  or  button to leave teletext.

## EDITING CHANNEL LIST

Select the “Edit TV-Channellist” menu using the menu button , the   buttons on the main menu and .







Also note the bars at the bottom of the on-screen display! These provide information on what to do next.











## SELECTION OF THE LIST/CHANNEL TO BE EDITED

Press the  (blue) button to switch between the TV and radio channel lists. Radio channels are edited in the same way as TV channels.

Editing favourite lists is explained as a separate item.

### Selection options:

-  (blue) button      Switch between radio and TV channels
-  (green) button      Open satellite channel lists
-  (yellow) button      Open the channel lists, sorted alphabetically
-  button      Search for a specific channel (enter the search expression using the number buttons on the remote control, see also the sections “Operating Instructions” “Alphanumeric Entries”)

A channel list is selected in the related category (satellites, favourites and alphabetic) using the   buttons (as standard the “All Satellites” channel list is displayed). Selection of channels in the list is performed using the cursor buttons (   ). The   buttons allow you to select individual channels, and the   buttons allow you to scroll from page to page of the currently selected list.

# EDITING CHANNEL LIST



## EDITING LIST/CHANNELS



When you have selected the channel or channel list to be edited, press the  (red dot) button to open the edit menu. You have the following edit options:



- **Move:**  
Channel can be moved within the current list to another channel slot
- **Delete:**  
Delete the channel from the current list
- **Skip:**  
Channel will be skipped when zapping through the channels
- **Lock:**  
Channel can be viewed only by entering a PIN
- **To favourite:**  
A channel can be assigned to any favourite list
- **Start Blockselection:**  
Several channels can be selected at the same time and edited together











As soon as you exit the menu under which you made the edit changes, you will be asked if you wish to save the changes. Use the   buttons to select either "Yes, save changes" or "No, don't save changes". Confirm your selection with the  button.

## EDITING CHANNEL LIST





### “LAST FUNCTION” MEMORY

The last editing action performed is saved on the  button, so by pressing the  button you can apply the last selection to other channels without having to open the edit menu again. As soon as you leave the current display, this option is cleared and becomes available again only after the edit menu has been opened and an action selected.

### MOVING CHANNELS

Use the  buttons to select the channel to be moved on the channel list you have selected (use the  (green) button to switch to the overall list, use the  (yellow) button to switch to the alphabetically sorted list). Press the  button to open the edit menu and use the  buttons to select the “Move” function. Confirm the command by pressing the  button. The channel you previously selected will now be shown inset slightly from the left. Now use the cursor buttons () or the number buttons to select the new desired position for the channel, and confirm the new channel slot by pressing the  button.

### DELETING CHANNELS





Use the  buttons to select the channel to be deleted on the channel list you have selected. Press the  button to open the edit menu and use the  buttons to select the “Delete” function. Confirm the command by pressing the  button.



**A deleted channel can be recovered only by performing another channel search (see section “Channel Search”)!**

The channel you previously selected will be deleted (from the favourite lists also!).







### SKIPPING CHANNELS

Use the  buttons to select the channel to be skipped on the channel list you have selected. Press the  button to open the edit menu and use the  buttons to select the “Skip” function. Confirm the command by pressing the  button.

The channel you previously selected is now shown in grey text. When zapping the channels this channel will in future be skipped and no longer shown in the channel list (open using the  button). This function can be restored again using the edit menu (select: “Unskip”).









## EDITING CHANNEL LIST

### LOCKING CHANNELS

Use the   buttons to select the channel to be locked on the channel list you have selected. Press the  button to open the edit menu and use the   buttons to select the “Lock” function. Confirm the command by pressing the  button. You are now prompted to enter the PIN code (factory default setting: 0000).

The channel you previously selected is now shown with a padlock to its right. In future this channel can be viewed only by entering the four-digit PIN code. This function can be restored again using the edit menu (select: “Unlock”).







### COPYING CHANNELS TO THE FAVOURITE LIST



Use the   buttons to select the channel to be copied on the channel list you have selected. Press the  button to open the edit menu and use the   buttons to select the “To Favorite” function. Use the   buttons to select the favourite list to which the channel is to be copied. The channel remains in the satellite channel list. Confirm the command by pressing the  button.

The channel you previously selected is now shown with an “F” and a yellow field in the channel list. The “F” shows that it is a favourite channel; the black dot in the yellow field shows in which of the eight favourite lists the channel can be found.

See the item “Editing Favourite Lists” for information on how to delete a channel from a favourite list.

### STARTING BLOCK MARKING (MARKING SEVERAL CHANNELS)

Use the   buttons to select the channel from which you want to start selecting further channels. You can only select channels that are listed in succession in the channel list you have selected. Press the  button to open the edit menu and use the   buttons to select the “Start Blockselection” function. Use the   buttons to highlight the desired channels, starting from the previously highlighted channel and working upwards or downwards. The highlighted channels will be highlighted in yellow and marked with a tick on the left.

When you have highlighted the channels that you wish to select, press the  button to open the edit menu once again and use the   buttons to select the desired function (“Move”, “Delete”, “Skip”, “Lock” or “To Favorite”).

The selected function can now be used in the same way as described for the respective items in this section for a single channel.

# EDITING CHANNEL LIST

## EDITING FAVOURITE LISTS

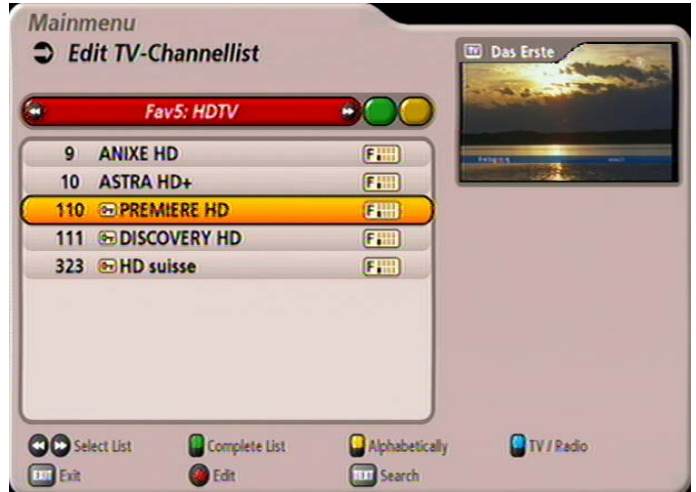

When you have selected the favourite list to be edited (open using the <sup>FAV</sup> (red) button and select using the buttons), press the (red dot) button to open the edit menu. You have the following edit options:

- **Remove from favoritelist:**  
The channel will be removed from the favourite list
- **Lock:**  
Channel can be viewed only by entering a PIN
- **Rename favoritelist:**  
The favourite list can be renamed
- **Start Blockselection:**  
Several channels can be selected at the same time and edited together







## REMOVING FROM FAVOURITE LIST

Use the buttons to select the channel to be removed from the favourite list you have selected. Press the button to open the edit menu and use the buttons to select the "Remove from favoritelist" function. Confirm the command by pressing the button.

The channel you previously selected is now removed from the favourite list (but not deleted from the overall satellite list).

## EDITING CHANNEL LIST







### LOCKING CHANNELS

Use the   buttons to select the channel to be locked on the favourite list you have selected. Press the  button to open the edit menu and use the   buttons to select the “Lock” function. Confirm the command by pressing the  button. You are now prompted to enter the PIN code (factory default setting: 0000).







The channel you previously selected is now shown with a padlock to its right. In future this channel can be viewed only by entering the four-digit PIN code. The channel is also locked on all other channel lists. You need not additionally lock the channel in the other channel lists.



This function can be restored again using the edit menu (select: “Unlock”).

### RENAMING FAVOURITE LIST

Use the   buttons to select the favourite list to be renamed. Press the  button to open the edit menu and use the   buttons to select the “Rename favoritelist” function. Confirm the command by pressing the  button. A keypad will now be displayed with which you can enter the desired name alphanumerically using the number buttons on the remote control. See also the section “Operating Instructions”, “Alphanumeric Entries”.

### STARTING BLOCK MARKING (MARKING SEVERAL CHANNELS)

Use the   buttons to select the channel as the start point from which you want to select further channels. You can only select channels that are listed in succession in your selected favourite list. Press the  button to open the edit menu and use the   buttons to select the “Start Blockselection” function. Now use the   buttons to highlight the desired channels, starting from the previously highlighted channel and working upwards or downwards. The highlighted channels will be highlighted in yellow and marked with a tick at the left side.

When you have highlighted the channels that you wish to select, press the  button to open the edit menu once again and use the   buttons to select the desired function (“Remove from favoritelist”, or “Unlock”).

The selected function can now be used in the same way as described for the respective items in this section for a single channel.

## SEARCHING FOR CHANNELS (CHANNEL SEARCH)

Select the “Search Channels” menu using the menu button **MENU**, the **▲▼** buttons on the main menu and **OK**.



Also note the bars at the bottom of the on-screen display! These provide information on what to do next.

You have three options for a channel search.

- Automatic Channel Search - all transponders for the satellite you selected will be searched
- Manual Channel Search - only the selected transponder for the satellite you selected will be searched
- Search with Service ID - Search for a specific channel using its service ID

Select the search type you want to rename using the **▲▼** buttons and confirm with **OK**.

## AUTOMATIC (CHANNEL) SEARCH

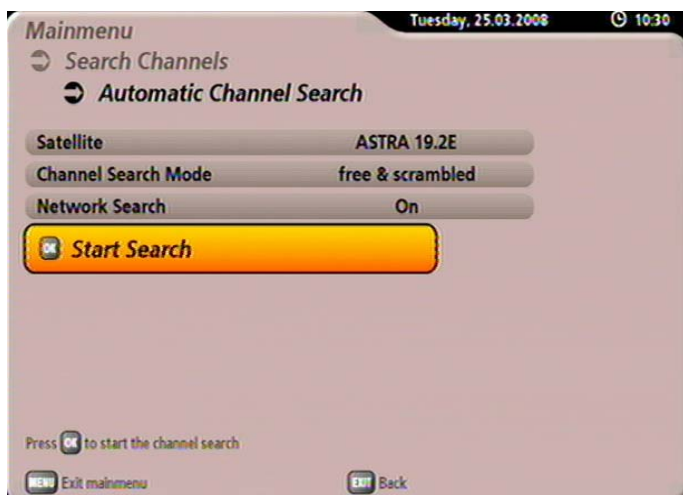



The **▲▼** buttons allow you to select different sets of parameters for the search.





# SEARCHING FOR CHANNELS (CHANNEL SEARCH)

## Satellite

Select the satellite to be searched, using the   buttons. Make sure your reception system is aligned to the selected satellite. You can search only one satellite at a time. If you have connected a multi-feed reception system (e.g. reception of ASTRA 19.2° East and HOTBIRD 13° East), you must repeat this procedure once for each satellite. You can however start the first installation again, in the course of which a channel search of all the satellites you selected is performed.

Press the  button to move to the next selection item.



## Channel Search Mode

Use the   buttons to select whether you wish to search “free & scrambled”, “free channels only” or “scrambled only” channels.





**To view scrambled channels you need the appropriate CA (Conditional Access) module and a valid smart card together with a valid subscription to the relevant pay TV provider.**

Press the  button to move to the next selection item.

## Network Search

Use the   buttons (On/Off) to select whether a network search should be performed. If you set the network search to “Off”, only the factory stored transponders of the satellites you previously selected will be searched for new as yet unlisted channels.

If you set the network search to “On”, the transponder network enables additional transponders that have not yet been stored to be located. They are then stored and searched for new channels in the same way as the existing transponders.

When you have made your settings, use the   buttons to select “Start Search” and press the  button to start the search. You can cancel the search at any time by pressing the  button. During the search you will see the following message (example):

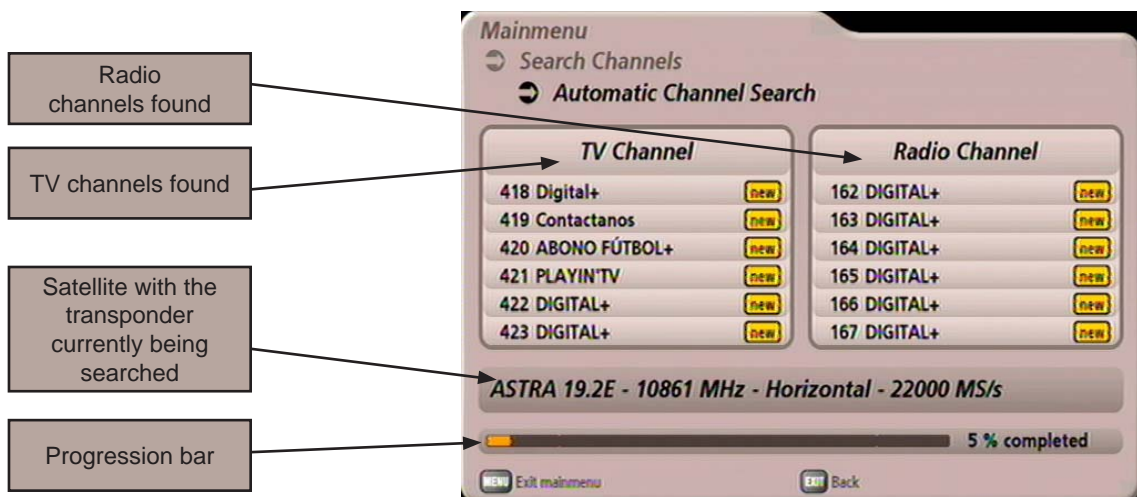

## SEARCHING FOR CHANNELS (CHANNEL SEARCH)

Newly found channels are identified with the designation “New” after the channel name. After completion of the search, you will see the following message (example):

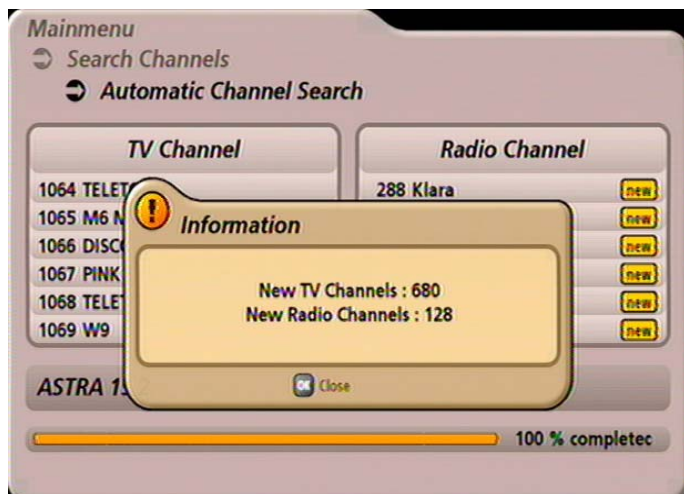

Press the **OK** button. You will be asked whether you wish to save the changes or not. Selection is performed using the **▲▼** buttons and is confirmed using the **OK** button. If you select “Yes, save changes”, the newly found channels will be added to the end of the channel list. Then press the **EXIT** button to exit the menu. The channel list is opened on to the TV screen by pressing the **OK** button (see also section “On-screen displays” “Channel list TV/Radio”).



After a search (of whatever type) the receiver shows all newly found channels in the channel list under the rubric “New Channels”. You will find this rubric in the channel list at the end of the green satellite channel lists (select using the **◀▶** buttons).

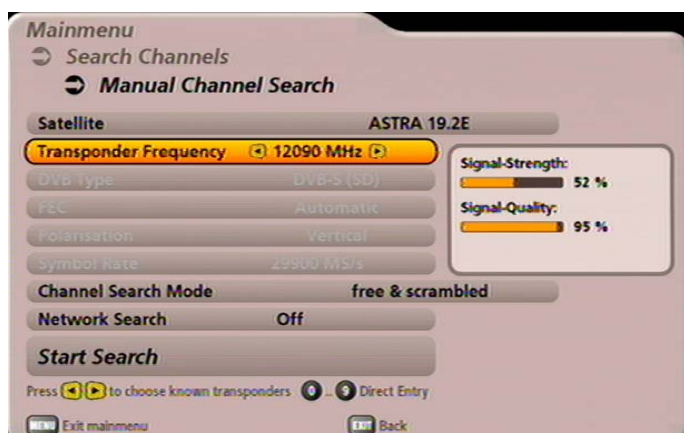

## MANUAL (CHANNEL) SEARCH



## SEARCHING FOR CHANNELS (CHANNEL SEARCH)



The   buttons allow you to select different sets of parameters for the search.

### Satellite

Use the   buttons to select the satellite on which the transponder you wish to search is located. Make sure your reception system is aligned to the selected satellite. You can search only one transponder at a time. If you wish to search several transponders on a satellite, you should start an automatic search of the transmitting satellite.

Press the  button to move to the next selection item.



### Transponder Frequency

Use the   buttons (transponder frequency already saved) or the number buttons (transponder frequency not yet saved) to select the transponder frequency on which the channel being sought is transmitted. At the bottom right of the screen display, the receiver shows the current signal strength and signal quality of the selected transponder.



Press the  button to move to the next selection item.

**The selection items: DVB Type, FEC, Polarisation and Symbol Rate need be entered only if the transponder has yet to be saved.**

### DVB Type

Press the   buttons to select whether the search should be for standard channels (DVB-S (SD)) or for HDTV channels (DVB-S2 (HDTV)).

### FEC

Press the   buttons to select the applicable error rate (Viterbi rate). There is no need to enter the error rate when searching for standard channels. Instead a fixed display of "Automatic" appears. When searching for HDTV channels you must enter the correct error rate (either QPSK 1/2, 2/3, 3/4, 3/5, 4/5, 5/6, 8/9, 9/10 or 8PSK 2/3, 3/4, 3/5, 5/6, 8/9, 9/10).



### Polarisation

Press the   buttons to select the correct polarisation (horizontal or vertical).

### Symbol Rate

Use the number buttons to enter the related symbol rate.

### Channel Search Mode



Use the   buttons to select whether you wish to search "free & scrambled", "free channels only" or "scrambled only" channels.

**To view scrambled channels you need the appropriate CA (Conditional Access) module and a valid smart card together with a valid subscription to the relevant pay TV provider.**





Press the  button to move to the next selection item.

## SEARCHING FOR CHANNELS (CHANNEL SEARCH)

### Network Search



Use the   buttons (On/Off) to select whether a network search should be performed. If you set the network search to “Off”, only the factory stored transponders of the satellites you previously selected will be searched for new as yet unlisted channels.



If you set the network search to “On”, the transponder network enables additional transponders that have not yet been stored to be located. They are then stored and searched for new channels in the same way as the existing transponders.

When you have made your settings, use the   buttons to select “Start Search” and press the  button to start the search. You can cancel the search at any time by pressing the  button. During the search you will see a display that shows you the progress of the search and the channels found so far. Newly found channels are identified with the designation “New” after the channel name.

After completion of the search, you will see the following message (example):

Press the  button. You will be asked whether you wish to save the changes or not. Selection is performed using



the   buttons and is confirmed using the  button. If you select “Yes, save changes”, the newly found channels will be added to the end of the channel list. Then press the

 button to exit the menu. The channel list is opened on to the TV screen by pressing the  button (see also section “On-screen displays” “Channel list TV/Radio”).



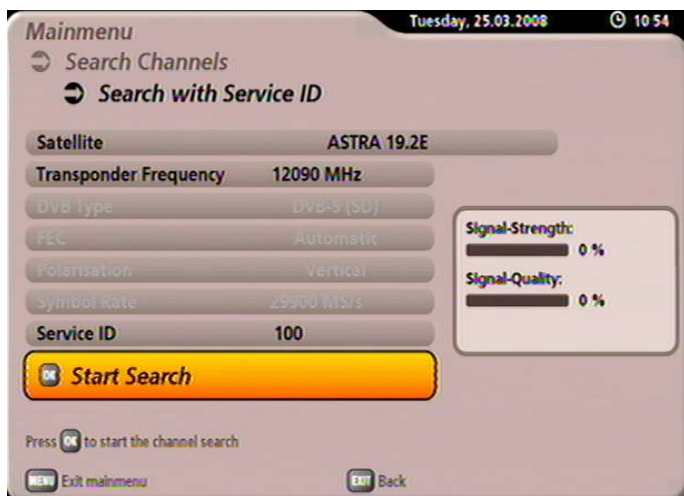

## CHANNEL SEARCH WITH SERVICE ID



The   buttons allow you to select different sets of parameters for the search.



### Satellite

Use the   buttons to select the satellite that is transmitting the channels to be searched. Make sure your reception system is aligned to the selected satellite.

## SEARCHING FOR CHANNELS (CHANNEL SEARCH)

Press the  button to move to the next selection item.

### Transponder Frequency



Use the   buttons (transponder frequency already saved) or the number buttons (transponder frequency not yet saved) to select the transponder frequency on which the channel being sought is transmitted. At the bottom right of the screen display, the receiver shows the current signal strength and signal quality of the selected transponder.

Press the  button to move to the next selection item.

**The selection items: DVB Type, FEC, Polarisation and Symbol Rate need be entered only if the transponder has yet to be saved (see manual (channel) search).**

### Service ID







Using the   buttons or the number buttons, enter here the service ID of the channel being sought.

When you have made your settings, use the   buttons to select "Start Search" and press the  button to start the search. You can cancel the search at any time by pressing the  button.





During the search you will see a display that shows you the progress of the search.

After completion of the search, you will see the following message (example):





Press the  button. You will be asked whether you wish to save the changes or not. Selection is performed using the   buttons and is confirmed using the  button. If you select "Yes, save changes", the newly found channels will be added to the end of the channel list. Then press the  button to exit the menu. The channel list is opened on to the TV screen by pressing the  button (see also section "On-screen displays" "Channel list TV/Radio").

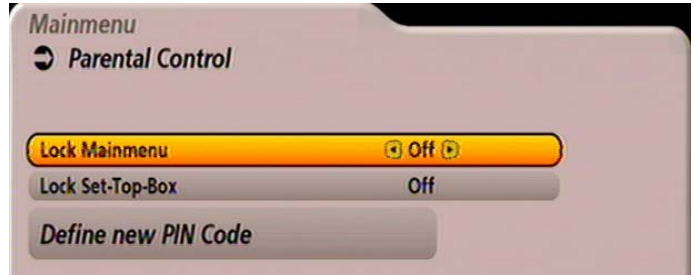

## PARENTAL CONTROL

Select the "Parental Control" menu using the menu button , the   buttons on the main menu and . You are now prompted to enter the PIN code (factory default setting: 0000). After entering the PIN using the number buttons the following display appears:





Select the parameters to be changed using the   buttons.

### LOCKING MAIN MENU

Use the   buttons (On/Off) to select whether the main menu should be locked. If the menu is locked, changes can be made only by entering the four-digit PIN code.

### LOCKING RECEIVER

Use the   buttons (On/Off) to select whether the receiver should be locked. If the receiver is locked, it can be operated only by entering the four-digit PIN code after it is switched on (factory setting: 0000).

Press the  button to exit the menu.

### SETTING A NEW CODE (PIN)

Press the  button to replace the old PIN code with a new one. Enter the new (four-digit) PIN. For security you must repeat the new PIN code once again.

Confirm the change of PIN code by pressing the  button.



**Keep your password in a safe place, so that you always have access to your channels even if you might have forgotten it.**

**If you have forgotten your password, you must contact your dealer, who will be able to unlock your receiver for you.**

# SETTINGS

The selected menus, sub-menus and positions, as well as the parameters to be set, are each highlighted in colour. The menus are largely self-explanatory.

Pay attention to the bar at the bottom of the on-screen display. These provide information on what to do next.

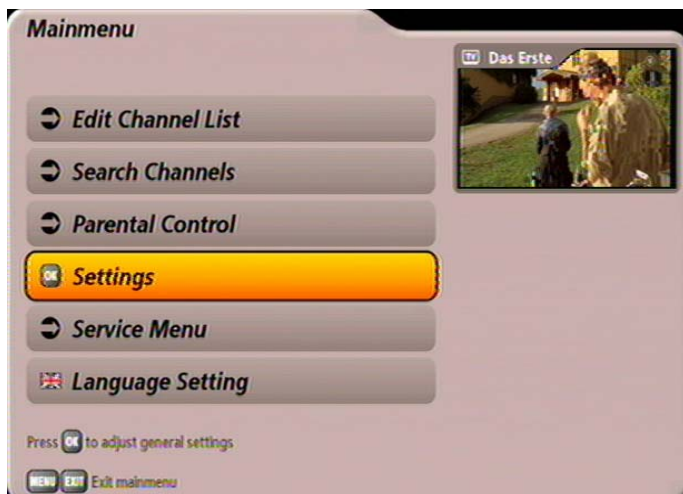

Select the "Settings" menu using the menu button **MENU**, the **▲▼** buttons on the main menu and **OK**.







Use the **▲▼** and the **OK** button to open the "TV, Video and Audio" menu. The following display appears (see next page):

Use the **▲▼** buttons to select the further options. If there is another sub-menu layer, press the **OK** button to open it. If there are no more sub-menus, make the settings using the **◀▶▲▼** buttons or the number buttons.

Press the **EXIT** button to save your settings and return to the previous menu. Press the **MENU** button to return directly to the TV picture, the changes will also be saved.

# SETTINGS

## TV SETTINGS

Use the     buttons here to select the settings for your TV set.

**When doing this, refer to the operating instructions for your TV set!**

### Video Output via

Select here the connection on the receiver to which you have connected your television.

Either

### SCART



or

### HDMI/YUV

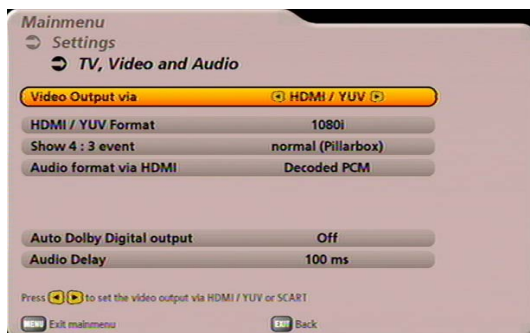

### TV aspect ratio

Here you select the TV's picture format. Either

- 4:3 or
- 16:9

### Picture format

Here you select the type of screen display, depending on the setting of your TV format:

- Pan & Scan
- Letterbox
- Automatically (only if the "16:9" TV format was selected)
- Always 16:9 (only if the "16:9" TV format was selected)

### TV-Scart-Output

Select the type of video signal at the TV Scart socket here. Select the signal that your TV set can process.

- FBAS – Color Video Baseband Signal
- RGB – Red/Green/Blue signal or
- Y/C – S-Video signal (luminance/chrominance)

### HDMI/YUV format

Select here the video resolution that is to be used on your TV. Either

- 1080i (resolution 1920 x 1080, half-screen images)
- 576p (resolution 720 x 576, full-screen images)
- 720p (resolution 1280 x 720, full-screen images) or
- Automatic

### Show 4:3 event

Select here the type of screen display for 4:3 programmes on a 16:9 TV:

- normal (Pillarbox)
- stretched (Fullscreen)
- zoom in (Pan & Scan)

*You can also open the settings for "Show 4:3 event" and for "HDMI/YUV Format" when viewing by pressing the  (green) button once.*

### Audio format via HDMI

Select here the type of audio signal that is to be output over the HDMI interface. Select the signal that your TV set can process.

- Decoded PCM
- S/PDIF format



# SETTINGS

SCART

or

HDMI/YUV

## Auto Dolby Digital OUTPUT

Here you can select whether the receiver should automatically output the Dolby Digital signal (if this is transmitted).

## Audio Delay (setting not currently available!)

Here you can set a delay in milliseconds, if the sound output from your receiver is out of synch with the TV picture (lip synchronicity). The delay can be set in 10 millisecond steps from 10 ms up to 200 ms.

## CUSTOMISING SCREEN MENU



## FUNCTIONS

Here you can configure the functions on of your receiver. You can choose between “High”, “Normal” and “Low”. The table on the following page shows which functions are available at each configuration step.

	FAV [Red Button] (red) button	OPT [Yellow Button] (yellow) button	TVR [Blue Button] (blue) button	[OK] button	[0] button
High	Favourites selection	Options selection	TV/radio	Channel list	Not assigned
Low	Not assigned	Not assigned	Not assigned	Programme Guide	Not assigned
Normal	Favourites selection	Options selection	TV/radio	Programme Guide	Not assigned

# SETTINGS



## CHANNEL OSD DURATION

Use the buttons to select the time after which you want the channel OSD to disappear automatically. The selections available are "Off", 1, 2, 3, 4, 5 or 6 Seconds.

## DISPLAY VOLUME BAR

Use the buttons (On/Off) to specify whether the volume bar is displayed when adjusting the volume.

## FRONT DISPLAY BRIGHTNESS

Use the buttons to set the brightness of the receiver front display. Select the most comfortable setting for the ambient lighting.

## FRONT DISPLAY IN STANDBY

Use the buttons to set whether the receiver front display should be switched on or off in stand-by mode (display of time).

## ADJUST MENU ON TV

Press the button to align the on-screen displays on the TV screen. Now you can use the cursor buttons

(, , , ) to determine the position of the on-screen display. When you have achieved the desired position,

press the button to fix the desired position.



# SETTINGS

## DATE AND TIME



### Local time offset (UTC)

Use the buttons to set the time zone variation from UTC (formerly GMT) (e.g. for Germany +1 hour).

Use the buttons to switch to the "Automatic clock change" field.

### Automatic time setting

Use the buttons to select whether the receiver should automatically change over between summer and winter time. If "On" is selected, the receiver automatically sets itself to the right time. If you select the setting "Off", you must make the change to and from summer time yourself, using the

"Summertime" field displayed below. Press the buttons to perform the setting.

### update time on

After opening this menu, the currently selected time update setting is displayed (see example above "Das Erste" or "all channels").

There are two ways (selection using the buttons) you can update the time using the receiver.

1. You select a specific channel for the time update. The time is only updated from this channel (in the example above "Das Erste" is selected)
2. "all channels" setting. The time information is always drawn from the channel currently selected.

Changing the setting for a specific channel:

If you want to change the time update from the channel currently set to another channel, you must first select the required channel and then open the "Date and Time" menu. In the "update time on" line select the "actual Channel e. g. (ZDF)" setting.

Press the button to exit the menu again.

## COMMON INTERFACE

See "Common Interface" section

## ANTENNA CONFIGURATION

See "First Installation" section, pages 14ff

## SERVICE MENU

Select the “Service” menu using the menu button **MENU**, the **▲▼** buttons on the main menu and **OK**. The following display appears:

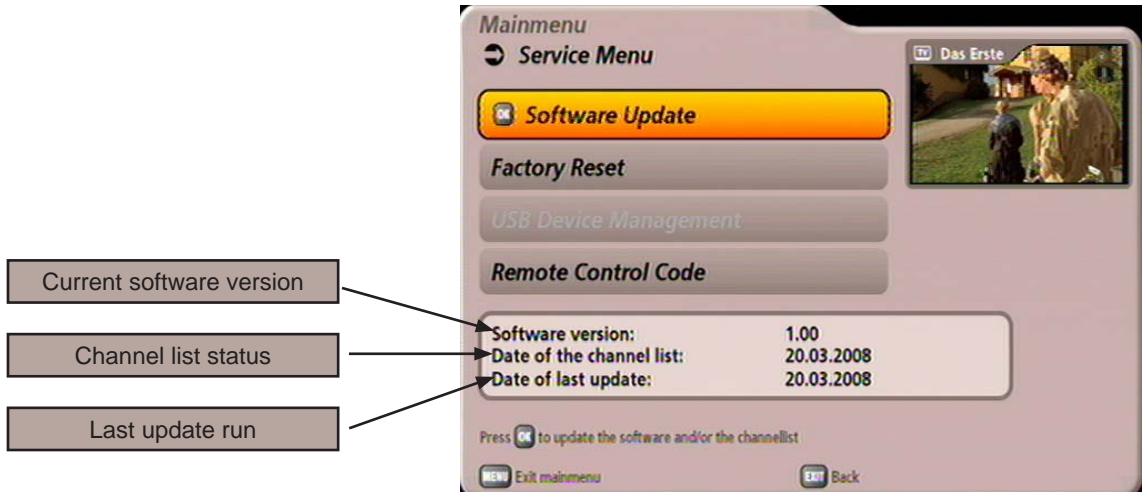

## SOFTWARE UPDATE

You can also check manually whether new software is available.

Use the **▲▼** buttons to switch to “Software Update“ and then press the **OK** button. The following display appears:



# SERVICE MENU

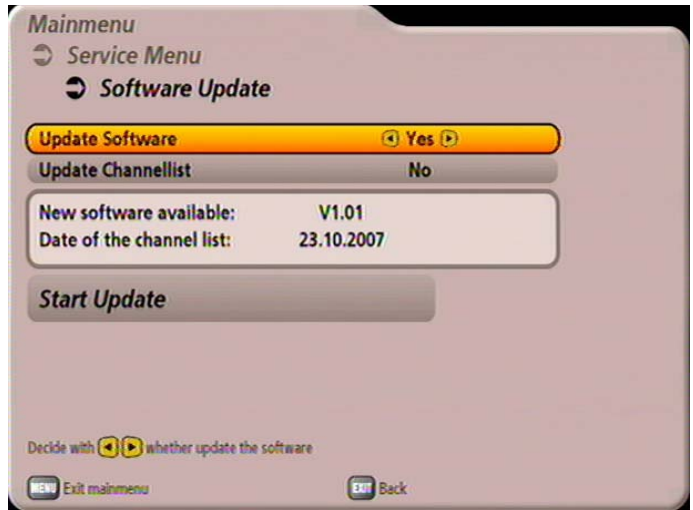

Also note the bars at the bottom of the on-screen display! These provide information on what to do next.

## Updating software

If new software is available (but only then), use the [left/right] buttons (No/Yes) to select whether you wish to load the new software that is available. If you are unsure whether you wish to load the new software, you can initially set the reply to “No”. If you do agree to the changes, you can then proceed to download the software.

## Updating channel list

If a new channel list is available (but only then), use the [left/right] buttons (No/Yes) to select whether you wish to load the new channel list that is available.

When you have made your settings, use the [up/down] buttons to select “Start Update” and press the [OK] button to start the update.

The following display appears (example):



## SERVICE MENU

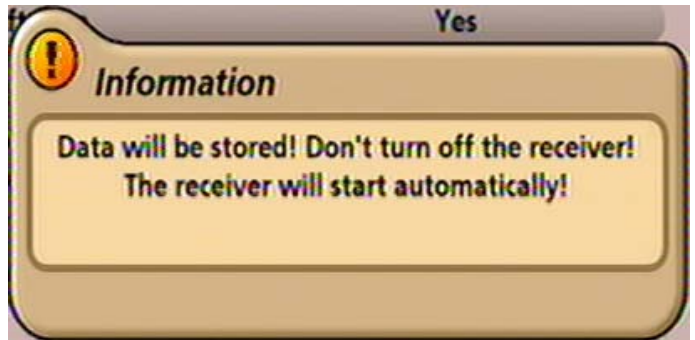
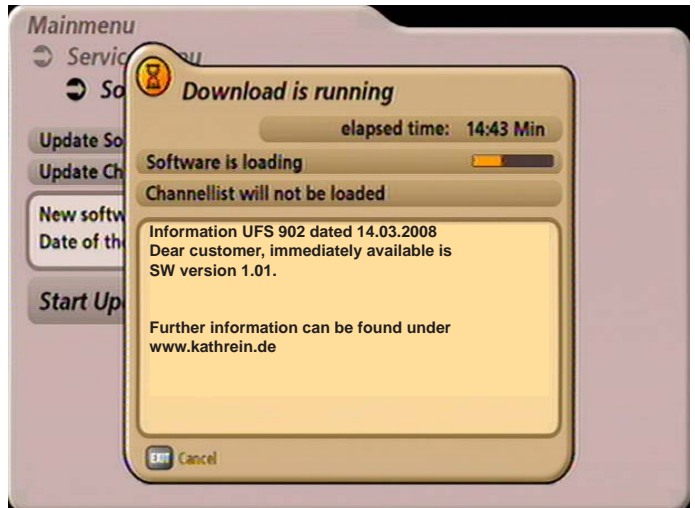

## FACTORY RESET

Select the "Service" menu using the menu button **MENU**, the **▲▼** buttons on the main menu and **OK**. Use the **▲▼** buttons to switch to "Factory Reset" and press the **OK** button. The following display appears:

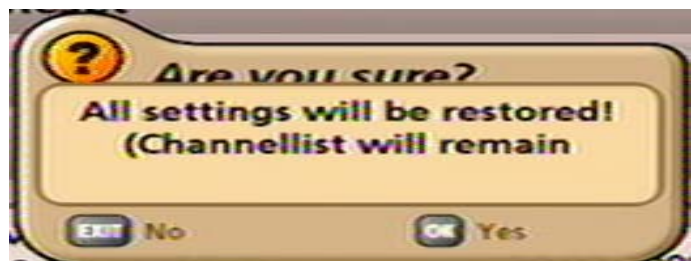

Press the **OK** button to load the factory default settings. The channels and favourite lists remain unchanged.



# SERVICE MENU

## USB DEVICE MANAGEMENT

This function is not currently supported/activated.

## REMOTE CONTROL CODE



Select the "Service" menu using the menu button , the   buttons on the main menu and .

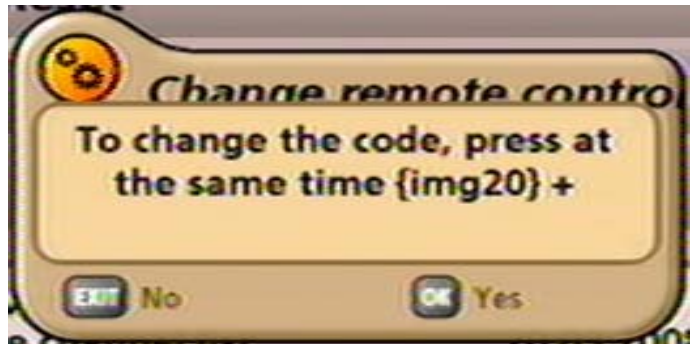

Use the   buttons to switch to "Remote Control Code" and to open press the  button. The following display appears:





You can now use the remote control for your receiver to set a new remote control code. Simultaneously press buttons

 +  +  for remote control code 1 (standard setting)



 +  +  for remote control code 2



 +  +  for remote control code 3

 +  +  for remote control code 4

After changing the remote control code you must now set your remote control to the code you selected. For this, simultaneously press buttons

 +  for remote control code 1

 +  for remote control code 2

 +  for remote control code 3

 +  for remote control code 4

Then press the  button. If the receiver display does not close down, the receiver and the remote control are not set to the same remote control code. Check your settings again.

## OPERATING FROM THE FRONT PANEL

If you have misplaced your remote control, or if the batteries are flat, you can still operate your receiver from the front panel.

### BACKUP OPERATION



There are four buttons on the front of the receiver.

#### **Stand-by button:**

You can switch off the receiver by pressing the “Stand-by” button (from operating mode to the stand-by mode) and back on again (from the stand-by mode to the operating mode).

#### **TV/R button:**

You can change between the TV and the radio mode using the TV/R button.

#### **▼ ▲ button:**

By pressing the ▼ ▲ buttons you can select the channels on the currently selected channel list in order without using the remote control.



Because there are no number buttons, no password/PIN-protected functions can be displayed.



# TECHNICAL APPENDIX

## FEATURES

- Reception of digital satellite TV channels and radio programmes in DVB-S and DVB-S2 transmission standards
- Video decoding of MPEG-2 and MPEG-4/H.264 signals
- 12-character alphanumeric display shows channel names and transmitter information
- 4,000 channel memory positions
- Kathrein Convenience EPG with timer programming <sup>1)</sup>
- Common Interface for one CA module <sup>2)</sup>
- HDMI output for connecting a HDTV-capable TV set
- Up-scaler for upscaling the Pal signal to 576p, 720p and 1080i
- Guided first installation
- Pre-programmed channel list
- Optical audio output for Dolby Digital data stream (AC 3)
- YPbPr output
- Cinch sockets for AV signals (composite FBAS, stereo audio)
- One USB 2.0 port on the rear of the unit
- 8 favourite channel lists for TV and 8 for Radio
- 1,000 timers (series and interval timers)
- Comp. colour, RGB and Y/C signal output programmable via Scart socket
- Software updates via satellite and from a USB stick (both the operational software and the programme lists can be updated)
- Language selection for multilingual broadcasts
- On-screen display (OSD) in 10 languages (D, GB, F, I, E, CZ, NL, PL, TR, RUS)
- DiSEqC™1.0 control signal and SCR single cable control signals
- Operating system based on LINUX
- Power switch
- Product package: Infrared remote control, batteries, operating manual, safety instructions, Scart cable, power supply cable

<sup>1)</sup> Display of information only if broadcast by the programme provider

<sup>2)</sup> CA modules and Smart cards not included

# TECHNICAL APPENDIX

Type	CE	UFS 902si	UFS 902sw
Order no./colour		20210129/silver	20210130/black
<b>RF range</b>			
Sat IF band	MHz	950-2150	
Input level band	dB $\mu$ V	44-83	
Reception threshold (EB/NO)	dB		
<b>TV system video</b>			
Modulation, FEC, demultiplexer		DVB-S/DVB-S2 standard	
Video resolution		CCIR 601 (720 x 576 lines), 576p, 720p, 1080i	
Video decoding		MPEG-2-, MPEG-4-compatible	
Input data rate	MSymb/s	2-45	
Bit rate	MBit/s		
Frequency range	MHz		
Output voltage	V <sub>pp</sub>		
S/N	dB	> 53	
<b>TV system audio</b>			
Decoding		AC 3, MPEG-4 (AAC-HE), MPEG-1, layer 1, 2 and 3	
Sampling rate	kHz	32/44.1/48	
Frequency range	kHz		
Output voltage	mV <sub>pp</sub>		
S/N	dB	> 65	
<b>Memory</b>			
Flash-RAM/SDRAM	MB	32/128	
Processor clock speed	MHz	200	
<b>Power supply</b>			
Mains voltage	V/Hz	100-240/50-60	
Power consumption (power/standby)	W	< 26/1	
LNB supply (horiz./vert.)	V/mA	14/18; max. 400	
Control signal	kHz	22; ToneBurst; DiSEqC™1.0	
<b>Connections</b>			
Sat IF input/output		2 x F sockets	
TV/VCR connection		1 x Scart sockets	
Video output (analogue)		3 x Cinch socket (YPbPr)/1 x Cinch socket	
Video/audio output (digital)		1 x HDMI	
Audio output (analogue/digital)		2 x Cinch sockets/SPDIF	
<b>Data interface</b>			
Common Interface		For 1 CA module	
USB		1 x 2.0	
RS 232		1	
<b>General</b>			
Ambient temperature	°C	Max. + 5 to + 40	
Unit dimensions (W x H x D)	mm	342 x 67 x 273	
Weight	kg	< 3	

## TECHNICAL APPENDIX

### SCART SOCKET ASSIGNMENT

Signal	Pin no.	TV
Audio right output	1	X
Audio right input	2	
Audio left output	3	X
Audio earth	4	X
Blue earth	5	X
Audio left input	6	
Blue signal	7	X
Switching voltage	8	X
Green earth	9	X
Data signal	10	
Green signal	11	X
Data signal	12	
Red earth	13	X
Data earth	14	
Red signal (C)	15	X
Blanking signal	16	X
Video earth	17	X
Blanking signal earth	18	X
Video output (FBAS/Y)	19	X
Video input	20	
Connector shield	21	X

### VHS/S-VHS SWITCHING

The Scart socket can be switched between VHS and S-VHS. The switch is made by selecting "Mainmenu", "Settings", "TV, Video and Audio".

For VHS (RGB): The red signal is connected to terminal 15, the composite colour output to terminal 19.

For S-VHS (C/Y): The Y output is connected to pin 19, the C output to pin 15.

# TECHNICAL APPENDIX

## CONNECTION EXAMPLE

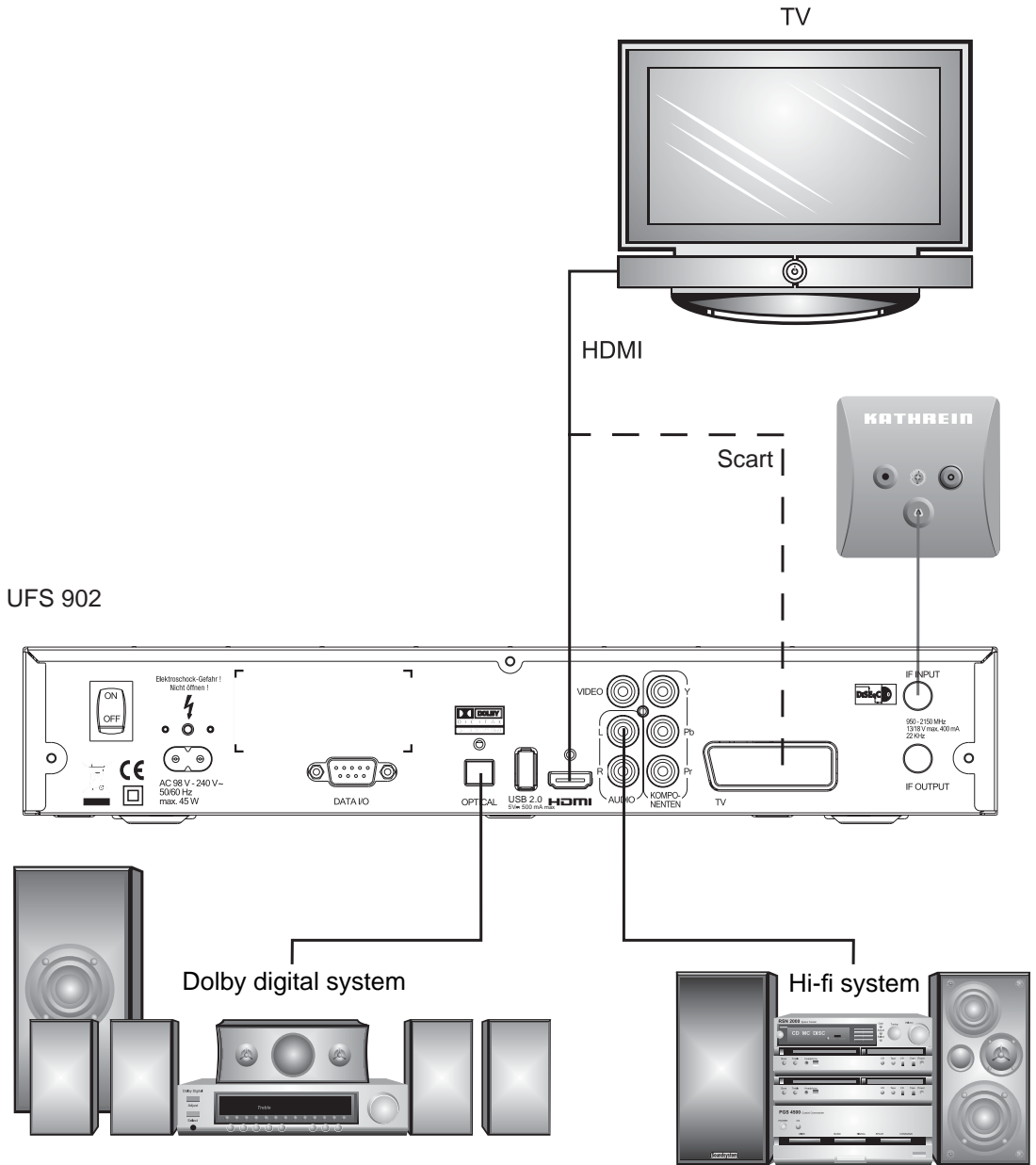

# TECHNICAL APPENDIX

## EXAMPLES single-cable systems

# EXR 501/551/552

### Single-cable switching matrices

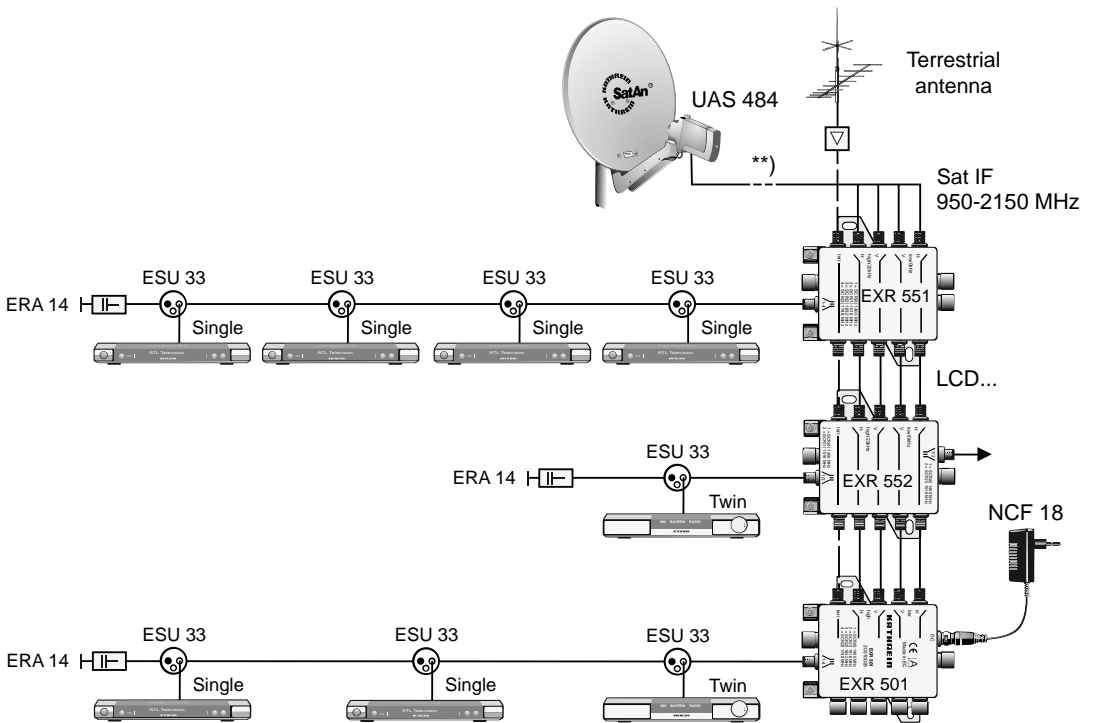

# UAS 481

Single-cable feed system

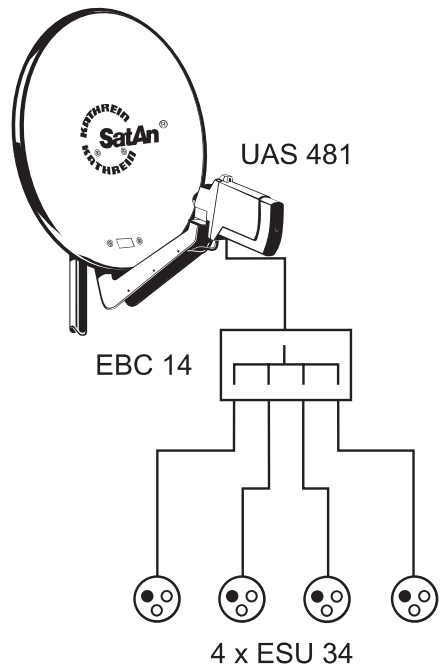
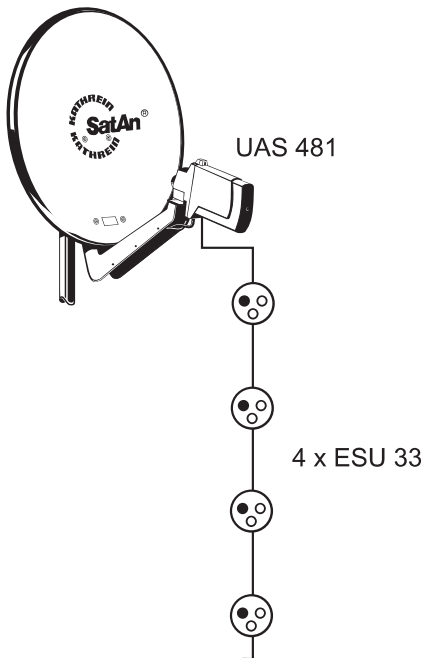
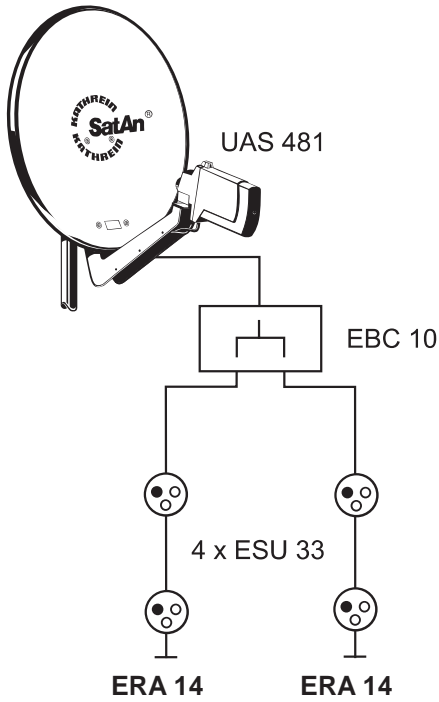

## EXU 908

### Single cable matrix

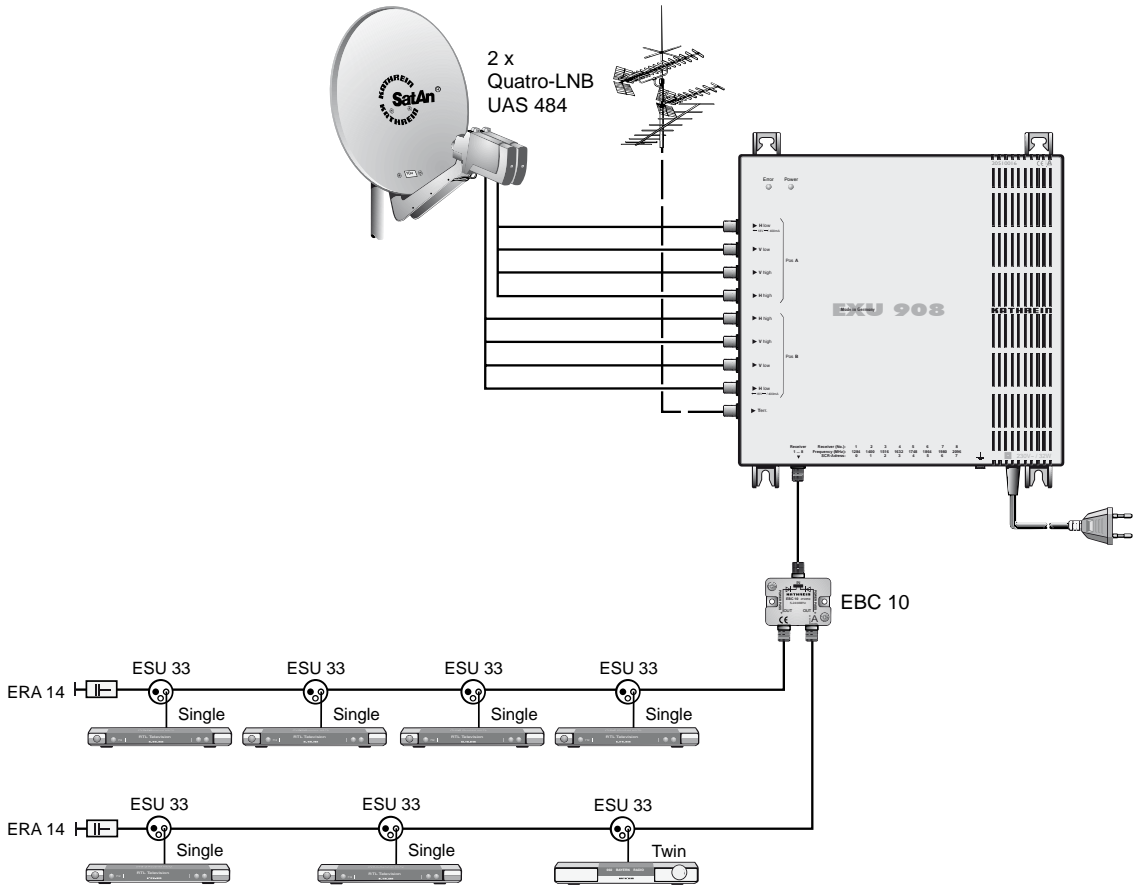

# SHORT TECHNICAL GLOSSARY

## **AC3**

Output for Dolby Digital signal

## **ASTRA**

SES (Société Européene des Satellites) satellite system. Analogue and digital transponders in the frequency range 10.7-12.75 GHz.

## **AV programme slot**

Preferred programme slot on TV set for external connections such as Scart and HDMI

## **CAM – Conditional Access Module**

Decryption decoder, which uses a smart card to decrypt the coded radio and TV signals.

## **CI - Common Interface**

Internationally standardised interface for CA modules

## **Conditional Access (CA) system**

Controls user access to services and programmes which are scrambled for reasons of copyright or for commercial reasons.

## **Data rate**

Data bits transmitted per second. Is expressed in kbit/s or Mbit/s. The higher the data rate the better the quality of the transmitted signal.

## **Data reduction**

Compression of video and audio signals. Redundant information is discarded.

## **DiSEqC™**

DiSEqC™ (Digital Satellite Equipment Control) is a communication system between a satellite receiver (master) and the peripheral satellite components (slaves), such as LNBS, multi-switches, rotating antenna systems.

It is a single master/multi-slave system, i.e. there is only ever one master in the satellite system. All activities start from the master.

## **DiSEqC™ components**

If DiSEqC™ switching matrices are cascaded, the master receiver must transmit the DiSEqC™ signal several times, so that all DiSEqC™ multi-switches in the cascade receive their commands.

These days, DiSEqC™ components (slaves) must be reverse compatible, i.e. respond to the analogue switching criteria from receivers that are only equipped with H/V and 22 kHz control signals.

A DiSEqC™ switching matrix will work with analogue switching criteria until the DiSEqC™ command from the master is received. All analogue switching criteria are then ignored.

## **Dolby Digital 5.1**

Dolby Digital is a sound transmission that allows digital surround sound to be output on a home cinema system.

## **DVB - Digital Video Broadcasting**

DVB-S refers to the transmission method (S = satellite, C = cable, T = terrestrial).

## **DVB-S2**

An enhanced DVB-S signal for HDTV with better quality.



# SHORT TECHNICAL GLOSSARY

## **Eb/No ratio**

The Eb/No ratio is a measure of the signal to noise ratio of a digital signal. The value is not identical to the C/N value familiar from analogue reception technology. At Eb/No values below 5 dB no reception is normally possible.

## **EUTELSAT**

European Satellite operator, based in Paris. Many orbit positions and European customers. Transponders in the frequency range 10.7-12.75 GHz.

## **FEC**

FEC is the abbreviation for "Forward Error Correction". A technique for reducing the error rate of data transmission. Additional bits are inserted into the data stream, so that error-correction algorithms can be used on reception. The FEC error rate corresponds to the Viterbi rate.

## **HD – Ready**

This is a label created by the EICTA (European Information, Communications and Consumer Electronics Industry Technology Association) for equipment that is capable of reproducing HDTV.

## **HDCP – High-bandwidth Digital Content Protection**

Scrambling system which protects the HDMI and DVI interfaces for secure transmission of video and audio data. HDCP should be used in Europe for HDTV standard transmissions.

## **HDMI – High Definition Multimedia Interface**

Digital interface for digital video and audio data transmission (preferred for HDTV).

## **HDTV – High Definition Television**

High resolution television with a resolution 6 times higher or finer than PAL or NTSC. However, there is no compatibility, as the transmission process DVB-S2 and the compression technique MPEG-4 are used for broadcasting.

The principal features of HDTV are the larger picture format (16:9), twice the number of scan lines (currently 625, increased to 1,250) and digital sound quality.

## **High band**

Satellite frequency range between 11.7 GHz and 12.75 GHz.

## **H.264**

Another designation for MPEG-4.

## **LNB - Low Noise Block Converter**

Converts the satellite downlink frequencies to 1<sup>st</sup> Sat IF.

## **Low Band**

Satellite frequency range between 10.7 GHz and 11.7 GHz.

## **MPEG-2**

MPEG is the abbreviation for Moving Picture Experts Group, a working group that formulates internationally applicable standards for the digital compression of video and audio. MPEG-2 has established itself as the standard for compression of digital TV signals. MPEG-2 works up to a data rate of 100 Mbit/s.

## **MPEG-4**

A further development of MPEG-2 with even higher data compression, intended for HDTV transmissions.

# SHORT TECHNICAL GLOSSARY

## **NID**

The channel identification number is also referred to as the Network ID or NID.

## **OSD – On-Screen Display**

Displays by the receiver on the TV screen (e.g. main menu)

## **PAL**

Analogue TV standard

## **Pay TV**

Television channels available on subscription (e.g. PREMIERE). Scrambled transmitters which can be decrypted only by using the appropriate smart card. As a rule these services are subscription-only.

## **PCMCIA**

Standard for internal decoder interface for pay TV

## **PID**

The PID (Packet IDentification) number is an identification number for video signals and audio signals in the digital data stream of DVB-MPEG-2 signals. The receiver uses the PID number to create a unique assignment for the video and audio data transmission. The PCR-PID is the identification number for the synchronisation signal. The PID-PCR is normally identical to the video PID. For programmes broadcast in multiple languages, the audio PD can be entered manually to assign a different language to the TV programme. After the PID is entered, the digital receiver automatically selects the audio data identified by the PID number from the data stream and assigns it to the video signal.

## **PIN**

Personal Identification Number. For this unit the PIN is a 4-digit numeric code which must be entered to unlock the unit to allow access to certain functions and channels.

## **Programme package**

The channel package for a digital transponder normally includes several TV and radio channels. Each channel package has a fixed assignment for the transponder transmission frequency, for polarisation (horizontal or vertical), for the symbol rate and for the Viterbi rate or error rate.

## **QAM - Quadrature-Amplitude-Modulation**

Digital modulation process with phase shift keying, which is used for transmissions in cable networks.

## **QPSK - Quadrature Phase Shift Keying**

Digital modulation process used for satellite transmission. (8PSK is also used in connection with HDTV)

## **Receiver**

Receiver

## **RGB**

Video signal made up of three individual colour signals (red, green, blue)

## **SAT IF signal**

Receiver input signal

## **Scart cable**

21-pin connecting cable (e.g. receiver/TV)

# SHORT TECHNICAL GLOSSARY

## **Smartcard**

Card from pay TV provider for decoding its programmes

## **Stand-by**

Standby mode

## **Symbol rate**

The symbol rate describes the quantity of data that is transmitted per second. The symbol rate is measured in MSymbols/s and is equal to the number of symbols received per second.

## **Time-shift function**

Timeshifted playback

## **Timer function**

Clock function for pre-programmed switch on and off times

## **Transponder**

A transponder is a frequency converter which receives TV and radio signals broadcast from the earth, converts them and then rebroadcasts them to the earth at a different frequency. A satellite has several transponders.

Analogue transponders transmit only one TV channel and possibly multiple radio channels on a single transmission frequency.

Digital transponders simultaneously transmit several TV and several radio programmes on a transmission frequency. If a programme provider is broadcasting several TV channels via a digital transponder, we refer to the provider's channel package. The terms "digital transponder" and "channel package" have the same meaning.

## **VCR/DVR connection**

Connection for an external recorder (such as a video or DVD recorder)

## **Video bit rate**

The video bit rate describes the quantity of data from the digitised video signal that is transmitted per second.

## **Viterbi rate**

The Viterbi rate (code rate, error rate) characterises the error protection used by the programme provider. The DVB standard provides the following values: 1/2 - 2/3 - 3/4 - 5/6 - 7/8

# SUBJECT INDEX

ADDITIONAL INFORMATION (i BUTTON).....	41
ALPHANUMERIC ENTRIES.....	31
ANTENNA CONFIGURATION .....	67
AUTOMATIC (CHANNEL) SEARCH.....	56
CATEGORIES VIEW .....	39
CHANNEL LIST - TV/RADIO .....	34
CHANNEL OSDS .....	32
CHANNEL SEARCH WITH SERVICE ID .....	60
COMMON INTERFACE .....	67
CONNECTION EXAMPLE.....	76
“CURRENT” VIEW .....	37
CUSTOMISING SCREEN MENU.....	65
DATE AND TIME .....	67
EDITING FAVOURITE LISTS .....	54
LOCKING CHANNELS .....	55
REMOVING FROM FAVOURITE LIST.....	54
RENAMING FAVOURITE LIST .....	55
STARTING BLOCK MARKING (MARKING SEVERAL CHANNELS).....	55
EDITING LIST/CHANNELS .....	51
COPYING CHANNELS TO THE FAVOURITE LIST.....	53
DELETING CHANNELS.....	52
“LAST FUNCTION” MEMORY .....	52
LOCKING CHANNELS .....	53
MOVING CHANNELS .....	52
SKIPPING CHANNELS .....	52
STARTING BLOCK MARKING (MARKING SEVERAL CHANNELS).....	53
ERROR MESSAGE .....	34
EXAMPLES SINGLE-CABLE SYSTEMS .....	77
FACTORY RESET.....	70
FEATURES .....	73
IMPORTANT INFORMATION .....	47
INSERTING THE SMARTCARD AND THE CA MODULE .....	47
LANGUAGE SELECTION - OSD .....	31
LOCKING MAIN MENU .....	62
LOCKING RECEIVER .....	62
MANUAL (CHANNEL) SEARCH .....	58
MENU CONCEPT .....	29
MENU TREE .....	30
OPENING MEDIA SELECTION (TV, RADIO ... ).....	33
OPENING OPTIONS CHANNEL.....	33
OPENING THE EPG .....	36
OPTION SELECTION.....	34
“PREVIEW” VIEW (PROGRAMME MAGAZINE).....	38
PROGRAMME INFORMATION.....	32
RECORDING (TIMER).....	42
RECORDING DAILY .....	43
RECORDING ONCE ONLY .....	43
RECORDING WEEKLY .....	44

## SUBJECT INDEX

RECORD USER-DEFINED.....	44
SERIES RECORDING .....	45
REMINDER FUNCTION (CHANGE OVER TO PROGRAMME).....	41
REMOTE CONTROL CODE.....	71
REMOTE CONTROL RC 660 .....	11
SCART SOCKET ASSIGNMENT .....	75
SEARCH FUNCTION .....	40
SELECTION OF THE LIST/CHANNEL TO BE EDITED .....	50
SERVICE .....	2
SETTING A NEW CODE (PIN).....	62
SOFTWARE UPDATE .....	68
TIMER LIST VIEW.....	46
TV SETTINGS .....	64
USB DEVICE MANAGEMENT .....	71
VHS/S-VHS SWITCHING.....	75
VIEW OF FRONT PANEL (FLAP FOLDED DOWN) .....	7
VIEW OF REAR PANEL.....	7

## TROUBLESHOOTING

In the event of a malfunction, first check all the cable connections and operating states:

1. Receiver and TV set power plugs are connected to wall socket
2. Antenna cables on receiver input
3. Receiver and TV set correctly connected by a Scart or cinch cable
4. Audio connections are made to Hi-Fi or Dolby Digital system as appropriate
5. Receiver and TV set (Hi-Fi/Dolby Digital system) are switched on (check power indicators)
6. Receiver is responding to remote control

A selection of troubleshooting tips is offered below.

Problem	Cause	Remedy
"No or bad signal!" warning appears on some or all channels	Antenna signal of satellite reception system missing or faulty. Incorrect LNB frequencies set in "Antenna Configuration" menu.	Consult an antenna specialist to have it checked and repaired as necessary. On "Installation" menu check LNB configuration for the satellite in question: High L.O. "10.600" GHz, Low L.O. "9.750" GHz, and Limit frequency L.O. "11.700 MHz", and change as necessary.
Remote control no longer responds	Receiver or remote control command set may have been unintentionally changed	Set infrared code 1, as described in operating manual under "Remote Control RC 660"; check batteries
Wrong time being displayed	The "Summertime" setting is wrong. An incorrect time was imported from the reception signal	Check summer time on the "Settings" - "Date and Time" menu, and change as necessary Switch off receiver at mains switch from current channel, e.g. ARD or ZDF, wait 10 seconds and then switch back on
The following channels cut out or "Poor signal or no signal!" appears: DSF, Tele 5, HSE 24 and Sonnenklar TV	DECT telephones are operating on the same frequency as these channels. Interference may occur due to inadequate level or poor shielding of cable	Consult your antenna specialist
Videotext cannot be called up using the TV set remote control	The Videotext signal is not being transmitted over the HDMI interface. The HDMI standard definitions do not provide for transmission of Videotext	Call up Videotext by pressing the  button on the receiver remote control, as described in the chapter "Videotext"

## SERVICE

If, despite studying this operating manual, you still have questions about getting started with the unit or using it correctly, or if unexpected problems occur, please contact your specialist dealer.

Internet: <http://www.kathrein.de>

KATHREIN-Werke KG • Anton-Kathrein-Straße 1 - 3  
P.O. Box 100 444 • 83004 Rosenheim • GERMANY

**KATHREIN**  
Antennen • Electronic

936.3352/B/1108/ZWT - Technical data subject to change.